



7 Selection Criteria: Modular Rotary Encoders Versus Bearing Encoders

Introduction

Modular rotary encoders are often used for closed-loop motor feedback. However, in many cases a rotary encoder with bearings is a better solution. This white paper offers an overview of selection criteria that will help you determine which type of rotary encoder is best for your application.

Modular, or "Kit", encoders are a specialized category of incremental rotary encoders. A modular encoder and what we'll call a "bearing encoder" differ in that the modular encoder has no internal bearings. Instead, it relies on the host device, typically a motor, to supply the structure necessary for proper operation. The sensor and disk are often separate assemblies that are installed on the motor shaft. This approach has its merits, since eliminating the bearings can lower the price of the encoder and flatten the encoder's profile, making it more compact. Thus, modular encoders are often favored by motor manufacturers due to cost and space constraints.

However, modular encoders sometimes can be a poor feedback choice, with compromised performance or even premature encoder failure the eventual result. The problem often stems from an incomplete understanding of the tradeoffs involved with modular vs. bearing encoders. When applying modular encoders, customers sometimes overlook several important considerations.



Critical Alignment

In order to produce reliable output signals, proper axial and radial alignment between the rotating disk and the fixed sensor must be established and maintained. This essential mechanical element is the main point of concern with modular encoders. In bearing encoders, this alignment relationship can be properly calibrated at the factory, and can be more easily maintained in the field.

Modular encoders are most commonly applied to motors. Since modular encoders do not have bearings, the motor's bearings and shaft assembly serve as the encoder's optical platform. Understandably, AC Motors are designed to be motors, and requirements for encoder sensors are not a leading concern for motor manufacturers. While newer encoder sensor technology is more forgiving of disk-to-sensor alignment, the motor must still meet certain criteria for optimum encoder performance and longevity. The two most common motor specifications that affect encoder operation are the shaft's axial movement (end float or end play) and the shaft's total indicated runout (TIR).

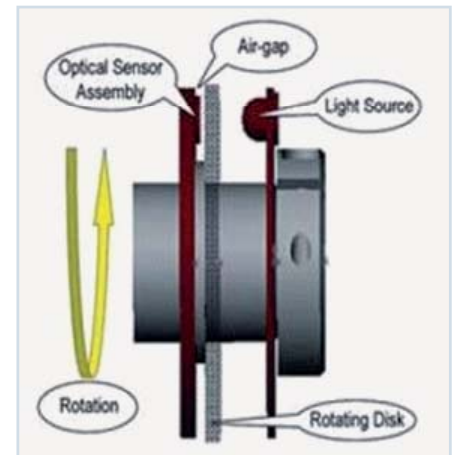

Axial Motor Shaft Movement (End Float or End Play)

End float refers to the amount of axial movement in the motor shaft. There are a number of factors that can contribute to axial motor shaft movement including part tolerances, bearing pre-load method, thermal expansion, and bearing wear over time. When a modular encoder is mounted, the amount of end float directly affects the encoder's air-gap (the distance between the sensor and the disk).

It can be difficult to obtain end float specifications from the motor manufacture, and even when you do, the information may not be completely accurate. Why? Some motor designs mechanically lock the shaft's axial movement on the feedback end so that end float is minimal. However, other motor designs often use a wave spring washer to take up any excess play and provide a pre-load force to the bearings. In this case, you cannot assume that the end float has been removed by the wave washer, since this is only true until an opposing axial force on the end of the shaft overcomes the spring force of the wave washer allowing the shaft to move. The results on a modular encoder mounted to this shaft could be disastrous, potentially causing the encoder disc to hit the sensor.



Two examples where this situation can occur are:

1. If a motor shaft is connected to a ball screw and the motor changes direction, the force from the ball screw will also change directions. This alternating force may cause the motor shaft to move axially.
2. If a sprocket, pulley, or gear with some side wobble is mounted on the motor shaft, the wobble may cause an alternating axial load to the motor shaft.

Total Indicated Runout (TIR)

Total Indicated Run-out (TIR) measures the radial range of shaft movement about its centerline. If an encoder is to be mounted on the motor shaft, TIR should be measured at the point that represents the furthest extent of the encoder case. For example, if the encoder is one inch thick, TIR should be measured about 1" from the motor face. Although many encoders with newer sensor technology will continue to operate as TIR increases beyond the specified tolerance, accuracy will be sacrificed.

Encoders with Bearings

Bearing-style optical encoders include internal bearings. With bearings, the amount of axial play is typically controlled to less than 0.0005". In addition, the disk is carefully aligned to the optics as part of the calibration procedure to keep radial run out less than 0.0002" typical. In this manner, the critical factors of end float and TIR are controlled and will not be affected by the motor shaft's end float or TIR in normal operation. A stainless steel flex mount allows the encoder to tolerate increased TIR and end float from the motor without sacrificing encoder performance or damaging its sensor, disk or bearings.

Selection Criteria

When deciding whether or not a modular or bearing encoder is the best solution for your application, consider these factors:

1. First and foremost, shaft end float and TIR must be within the encoder's specifications. This is so important that if you don't have (or can't get) this information, or don't trust what you have, then an encoder with bearings is strongly recommended, since it will be a much safer choice.
2. Modular encoders can be a good choice for high-speed applications, those above 10,000 RPM, because there are no speed limitations dictated by encoder bearings. For example, BEPC's Encoder Model 121 Modular Unit has been successfully operated at speeds in excess of 40,000 RPM. The speed limiting factor is the maximum frequency of the encoder, which is a function of disk resolution, RPM's and the signal processing circuitry. Most encoder manufacturers include maximum frequency in product specifications.
3. If the motor is to be used under considerable mechanical load, where the motor bearings could experience extra wear, then an encoder with bearings would be the better choice. Remember, the bearings of the host device, serve as the bearings of the modular encoder.
4. Modular encoders are difficult to seal. If your application requires wash-down, or if the operating environment is dirty, dusty or wet, then an encoder with bearings and seals should be your first consideration. Such environments effectively rule out modular encoders, unless external protection, such as an IP sealed motor cover, is used.
5. If your application requirements combine high maximum frequency (> 200kHz), high temperature (100C or higher), and higher resolution

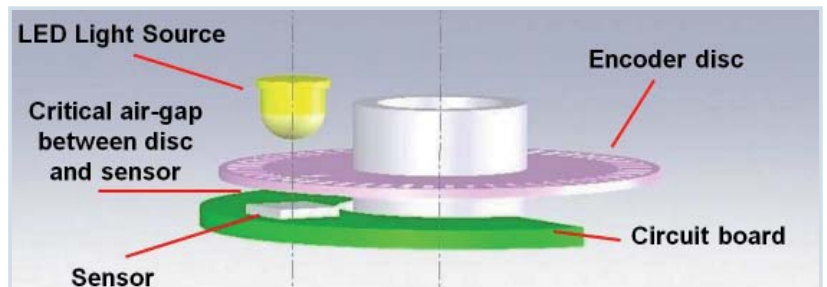



(>2048 PPR), then an encoder with bearings is recommended. For long term reliability, this combination of factors requires the air-gap between the disk and sensor to be very narrow and tightly controlled. An encoder with bearings simply provides a more stable optical platform.

6. Lower resolutions (up to 1024 PPR) are more forgiving of End Float and TIR, and are often well-suited for modular applications if the operating environment is appropriate.

7. If you plan to use numerous encoders, then the relatively lower price of a modular encoder could save you some money. On the other hand, the greater durability and easier installation of an encoder with bearings might be worth a slightly higher unit price. In any case, carefully weigh the factors of long term support costs versus lower acquisition costs before making your final decision.

Conclusion

Modular encoders can be an acceptable and effective feedback solution for many applications. However, in others, an encoder with bearings is the best choice in terms of performance and reliability. By assessing and addressing pertinent mechanical, electrical and environmental requirements, you can avoid costly and troublesome encoder failure or substandard performance.

If you do decide that a modular encoder is the right choice for your application, consider the Model 121 Self-Aligning Encoder.

The Model 121 has an innovative design that eliminates the installation and mounting hassles typical of other modular encoders. As a result, the Model 121 does not require calibration gapping or the use of special tools to install. Its three step installation is simple and quick. Also, the Model 121's all-metal construction will not warp or deflect, unlike plastic modular designs. These features combine to make the Model 121 a durable, accurate and cost-effective solution for many applications where a modular encoder is the preferred choice. Full product information and a complete data sheet are available on www.encoder.co.uk



Model 121

Quick Selection Chart

| Parameter | Attribute | Use Modular | Use Encoder with Bearings |
|--|---|--------------------------|---------------------------|
| Motor shaft end float and TIR | Within the encoder manufacturer's specifications | Yes | Yes |
| Motor shaft end float and TIR | Outside the encoder manufacturer's specifications | No | Yes |
| Motor shaft end float and TIR | Don't have the information or don't trust | Not suggested | Suggested |
| High-speed applications | Above 10,000 RPM | Good possibility | Not suggested |
| Severe duty application | Motor bearings have extra load and wear | Not suggested | Suggested |
| Dirty environment | May need seals | Not suggested | Suggested |
| Combination of high frequency response, temperature, CPR | >200kHz, >100°C, >2048 CPR | Not suggested | Suggested |
| Lower resolution requirement | <1024 cycles per revolution | Good possibility | Good |
| Number of units needed | Acquisition cost vs. life cycle cost | Consider if large volume | Good |

British Encoder Products Company
+44 (0)1978 262100
www.encoder.co.uk | sales@encoder.co.uk