



775/776

## Clamp Shaft Mounting

After carefully unpacking the unit, inspect and ensure that the motor shaft is the correct size and free of all burrs and aberrations.

**The maximum recommended motor axial endplay is  $\pm 0.07\text{mm}$ . Maximum motor TIR is  $0.012\text{mm}$ .**

### STEP 1

Slide the encoder over the motor shaft.

### DO NOT USE UNDUE FORCE

The encoder should be positioned approximately 1.58mm to 2.38mm from the mounting surface or until the anti-rotation flex arm contacts the motor surface. Install a flat washer and screw in the anti-rotation flex mount. **Do not over tighten.**

### STEP 2

Tighten the socket head screw in the clamping collar to the following torque range:

3.38 N-m to 3.95 N-m for Model 775  
1.69 N-m to 2.82 N-m for Model 776

When the motor shaft is turned by hand or operated the movement in the encoder housing should be very minimal.

### STEP 3 (Optional)

If the optional shaft cover is included, install it over the shaft and mount it to the encoder housing using the 4-40 screws. Make sure the screws are securely tightened.

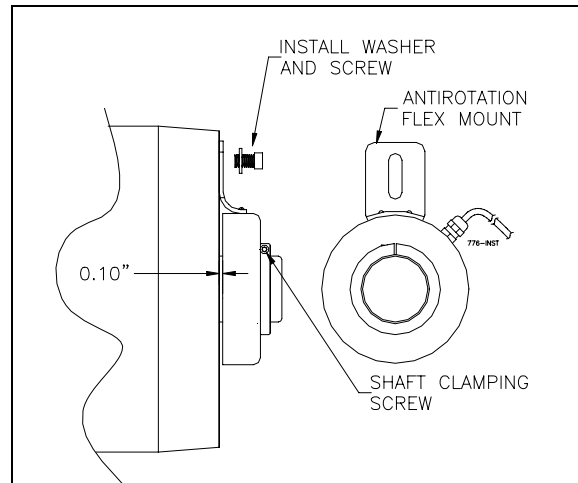

### IN CASE OF DIFFICULTY

Note 1: Make sure the socket head screw in the front of the encoder locking collar is loose and the collar is not cocked or jammed. Clean the shaft of any burrs using fine crocus cloth.

Note 2: When tightening the screw in the locking collar, avoid holding the motor shaft with anything that may scar or burr the shaft.

### REMOVAL

1. If the optional shaft cover is installed, remove it by removing the 4-40 screws that hold it in place.
2. Loosen (do not remove) socket head screw in the locking collar. Then remove the anti-rotation flex mount screw and slide the encoder off.

If you have questions regarding this Technical Bulletin, please call Technical Support at +44(0)1978 262100 or email [steve.dixon@encoder.co.uk](mailto:steve.dixon@encoder.co.uk)

TB-502.doc, Rev E, 05/02/02, BEPC Version