

EtherNet/IP[®]

TECHNICAL REFERENCE MANUAL

EtherNet/IP Interface

Absolute EtherNet/IP[™] Encoders

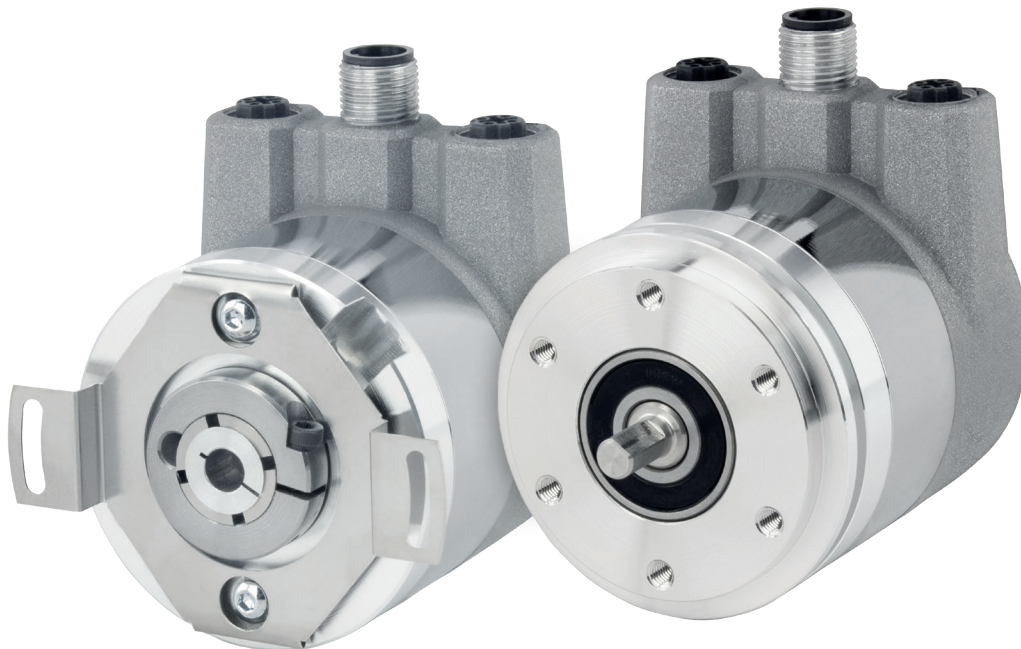

+44(0)1978 262100 | ENCODER.CO.UK | SALES@ENCODER.CO.UK

©2023 British Encoder Products Company. All rights reserved.

British Encoder Products Company

33 Unit, Whitegate Industrial Estate
Wrexham, LL13 8UG
UK

Phone: +44(0)1978 262100

Fax: +44(0)1978 262101

Email (UK): sales@encoder.co.uk

Website: encoder.co.uk

EtherNet/IP™ is a trademark of ODVA, Inc.

Warranty waiver, right of amendment, copyright:

Encoder Products Company (EPC) accepts no liability or warranty for the correctness of this manual, or for any direct or indirect damage that may arise from use of it. In the pursuit of constant innovation and cooperation with customers, EPC reserves the right to amend technical data or content at any time without prior notice to customers.

Table of contents

1. Introduction	6	6.3 Deactivating DHCP mode and assigning an IP address	37
1.1 About this manual.	6	6.4 Integration into a Studio 5000 project	41
1.1.1 Symbols	6	6.5 Further configuration options	62
1.1.2 You will not find the following in this manual:.	7		
1.2 Products covered	7	7. Technical data	65
1.3 Specifications.	7	7.1 Properties.	65
1.4 Contents of your order	8	7.2 Dimensions	65
2. Safety information	8	7.2.1 Model A58SE Clamping Flange (MH)	65
2.1 General safety information	8	7.2.2 Model A58SE Synchro Flange (MK)	66
2.2 Intended use	8	7.2.3 Model A58SE Clamping Flange Heavy Duty (MM)	66
2.3 Safe working	9	7.2.4 Model A58SE Clamping Flange Compact (MP)	66
2.4 Disposal	9	7.2.5 Model A58HE 63 mm 2-point flex mount (SR)	67
3. Device description.	9	8. Technical support	67
3.1 General information	9		
3.2 EtherNet/IP	10		
3.3 Absolute encoder basic principles.	10		
3.3.1 Single turn – ST.	10		
3.3.2 Multi-turn – MT.	10		
3.3.3 Direction of rotation.	10		
3.3.4 Preset.	10		
3.3.5 Scaling	11		
3.4 Connection assignments for EtherNet/IP encoders	12		
3.4.1 RNB – bus cover	12		
3.5 LEDs and signaling	12		
3.6 MAC address and IP address	13		
3.7 Programmable attributes	14		
4. EtherNet/IP	14		
4.1 Functions overview	14		
4.2 List of all classes	15		
4.3 Process and configuration data	15		
4.4 Class attributes.	20		
4.4.1.1 113d – CAM state register	25		
4.4.1.2 114d – CAM enable register	26		
4.4.1.3 115d – CAM polarity register	26		
4.4.1.4 116d...123d – CAM1...CAM8 low limit	27		
4.4.1.5 124d...131d – CAM1...CAM8 high limit	27		
4.4.1.6 132d...139d – CAM1...CAM8 hysteresis	27		
5. Webserver	27		
5.1 General	27		
5.2 Overview	28		
5.3 Configuration.	30		
5.3.1 Firmware update.	32		
5.4 License information.	35		
5.5 Contact	36		
6. Commissioning.	36		
6.1 General	36		
6.2 Activating DHCP mode	36		

Index of Figures

Figure 3.1: Model A58 encoders with EtherNet/IP™	9	Figure 6.41: Assembly 100.	63
Figure 5.1: Overview	28	Figure 6.42: Position state register inside work area	64
Figure 5.2: Versions	29	Figure 6.43: Position state register outside work area	64
Figure 5.3: Network.	30	Figure 7.1: Dimensions Model A58SE Clamping Flange (MH)	65
Figure 5.4: Encoder	31	Figure 7.2: Model A58SE Synchro Flange (MK).	66
Figure 5.5: Firmware update	32	Figure 7.3: Model A58SE Clamping Flange Heavy Duty (MM)	66
Figure 5.6: Firmware update – choose file	33	Figure 7.4: Model A58SE Clamping Flange Compact (MP)	66
Figure 5.7: Firmware update – transferring file	33	Figure 7.5: Model A58HE 63 mm 2-point flex mount (SR).	67
Figure 5.8: Firmware update – successful	34		
Figure 5.9: Firmware update – failed.	34		
Figure 5.10: License information	35		
Figure 5.11: Contact information	36		
Figure 6.1: Set MAC and IP address	37		
Figure 6.2: DHCP activated	37		
Figure 6.3: BootP DHCP tool	38		
Figure 6.4: Set IP address and device name.	39		
Figure 6.5: IP address and device name successfully set.	39		
Figure 6.6: DHCP deactivated	40		
Figure 6.7: Webserver available	40		
Figure 6.8: Main menu	41		
Figure 6.9: Tools -> EDS hardware installation tool	42		
Figure 6.10: EDS hardware installation tool	43		
Figure 6.11: Register an EDS file	43		
Figure 6.12: Select an EDS file	44		
Figure 6.13: EDS installation	44		
Figure 6.14: Installation successful	45		
Figure 6.15: Project navigation	46		
Figure 6.16: Hardware catalog.	46		
Figure 6.17: General	47		
Figure 6.18: Choose assembly	47		
Figure 6.19: Encoder configuration successful	48		
Figure 6.20: Position value	49		
Figure 6.21: Module definition	50		
Figure 6.22: Controller tags	50		
Figure 6.23: Configuration assembly.	51		
Figure 6.24: Example configuration	52		
Figure 6.25: Encoder information	53		
Figure 6.26: Example new program	54		
Figure 6.27: Parameters and tags	55		
Figure 6.28: Parameters and tags	56		
Figure 6.29: Rung edit	56		
Figure 6.30: Rung edit	57		
Figure 6.31: Rung edit	57		
Figure 6.32: Rung edit	58		
Figure 6.33: MSG block configuration	58		
Figure 6.34: MSG block path configuration.	59		
Figure 6.35: Configure the main program.	60		
Figure 6.36: Parameters and tags	60		
Figure 6.37: Configuration successful	61		
Figure 6.38: Webserver after successful completion	61		
Figure 6.39: MSG position low limit.	62		
Figure 6.40: MSG position high limit	63		

Index of Tables

Table 3.1: Connection assignment – RNB	12
Table 3.2: LED signals.	13
Table 4.1: Functions.	14
Table 4.2: List of all classes	15
Table 4.3: Process data overview	15
Table 4.4: Assembly 1.	16
Table 4.5: Assembly 2.	16
Table 4.6: Assembly 3.	17
Table 4.7: Assembly 100	17
Table 4.8: Assembly 101	18
Table 4.9: Configuration assembly 110	19
Table 4.10: Identity object.	20
Table 4.11: Position sensor object.	25
Table 4.12: CAM state register	25
Table 4.13: CAM state register	26
Table 4.14: CAM enable register	26
Table 4.15: CAM polarity register	26
Table 6.1: Configurations	59

1. Introduction

1.1 About this manual

This technical manual describes the configuration and mounting possibilities for absolute encoders with an EtherNet/IP™ interface for firmware versions greater than 1.06 produced by Encoder Products Company (EPC). It supplements the other publicly available EPC automation documents, e.g., datasheets, assembly instructions, leaflets, catalogs, and flyers.

Ensure that you read the manual before commissioning – check beforehand that you have the latest version of the manual.

When reading, pay particular attention to the information, important notices, and warnings that are marked with the corresponding symbols (see chapter 1.1.1).

This manual is intended for persons with technical knowledge in the handling of sensors, EtherNet/IP™ interfaces, and automation elements. If you do not have any experience in this field, request the assistance of experienced personnel before proceeding.

Keep the information provided with our product in a safe place so that you can refer to it later as necessary.



- The contents of this manual are arranged with practical use in mind.
- For optimum use of the device, all information in the following sections is important and should be read.

1.1.1 Symbols



- The INFO symbol indicates a section that contains particularly important information for advanced use of the device.



- The IMPORTANT symbol is shown next to a section of text that describes a method for solving a particular problem.



- The WARNING symbol indicates that the adjacent instructions must be observed to ensure correct use of the device and to protect the user against hazards.

1.1.2 You will not find the following in this manual:

- Basic information about automation technology
- System planning
- Risks (availability, safety)
- Shielding concepts
- Reflections
- Repeaters
- Network configuration
- Bus cycle times
- FMA management systems
- Transmission services
- Telegram types

1.2 Products covered

This manual relates to the following encoder types produced by Encoder Products Company:

- Model A58HE – EtherNet/IP™ absolute blind hollow bore encoder with bus cover
- Model A58SE – EtherNet/IP™ absolute shaft encoder, with synchro or clamping flange, in standard, heavy-duty, and compact models, with bus cover



- Encoder Products Company EtherNet/IP™ product information can be found on our website: encoder.com

1.3 Specifications

An encoder is a sensor that is designed to detect angular positions (single turn) and revolutions (multi-turn). The measured data and variables are processed by the encoder and provided as electrical output signals for the connected peripherals.

Patented technologies are used in the Model A58SE and A58HE encoders. As a result, the Model A58 series encoders from EPC are highly accurate, maintenance-free, and environmentally friendly.

The encoders whose article descriptions are listed in section 1.2 communicate via the EtherNet/IP™ interface.

1.4 Contents of your order

The contents of your order depend on the product variants and the details of your order. Before commissioning, check the contents of the delivery for completeness.

As a rule, the EPC Model A58 encoders with an EtherNet/IP™ interface include the following items:

- Model A58SE or A58HE EtherNet/IP™ encoder (with bus cover)
- Installation instructions



- The corresponding EDS file and datasheet can be downloaded at [encoder.com](https://www.encoder.com)

2. Safety information

2.1 General safety information



- When commissioning the encoder, ensure that you observe the assembly instructions, manual, and datasheet.
- Failure to observe the safety instructions may lead to malfunctions, property damage, and personal injury.
- Observe the operating instructions provided by the machine's manufacturer.

2.2 Intended use

Rotary encoders are components that are intended for installation in machinery. Before commissioning (operation in accordance with the intended use), it must be determined that the machine conforms to the EMC and Machine Directive.

A rotary encoder is a sensor that is designed to detect angular positions and revolutions and must only be used for this purpose. Encoder Products Company manufactures and distributes these encoders only for use outside of safety-related industrial applications.



- The encoder must not be operated outside the specified limit parameters (see datasheet).

2.3 Safe working

The installation and mounting of the encoder must only be carried out by a qualified electrician.

For the construction of electrical installations, all relevant national and international regulations must be strictly observed.

Failure to commission the encoder correctly may result in malfunction or failure.



- All electrical components must be tested before commissioning.
- Appropriate safety measures must be taken to ensure that no persons are harmed and no damage to the system or operating equipment occurs in the event of a failure or malfunction.

2.4 Disposal

Devices that are no longer needed or are defective must be disposed of by the user in proper compliance with country-specific laws. It must be taken into consideration that this is a special type of electronic device, and that disposal is not permitted via normal household waste.

There is no obligation by the manufacturer to take the device back. If you have any questions regarding proper disposal, contact a disposal specialist in your area.

3. Device description

3.1 General information

Various mechanical variants of the Model A58 series encoders with EtherNet/IP™ are available. The required variant is determined by the need for a bus cover, the flange design, and the shaft type (solid or hollow). The size is specified as 58 mm by the diameter at the flange. The following figure shows examples of Model A58 series encoders with EtherNet/IP™.



Figure 3.1: Model A58 encoders with EtherNet/IP™

The solid or hollow shaft is connected to the rotating component whose angular position or rotational speed is to be measured. Cable or plug outlets create the interface for connection to the EtherNet/IP™ network. The status LEDs, which are mounted in the cover, signal the various encoder states during operation. They assist with configuration of the encoder and troubleshooting in the

field. The flange holes or supplied flex mounts are used for attachment to the machine.

3.2 EtherNet/IP

EtherNet/IP™ is a real-time Ethernet, which was developed by Allen-Bradley and is managed today as an open standard by the Open DeviceNet Vendor Association (ODVA®). It is based on the CIP standard (Common Industrial Protocol) and is used for the transmission of cyclic I/O data, as well as acyclic parameter data.

EtherNet/IP™ offers different topologies, but mostly an active star or ring topology is used. With the ring topology, the DLR (Device Level Ring) can be used to prevent a total failure in the network due to a cable break, for example.

3.3 Absolute encoder basic principles

The following sections describe the basic functions of an absolute encoder. Unlike incremental encoders, absolute encoders output their position value as a digital number via a fieldbus. A distinction is made here between single turn and multi-turn encoders.

In addition to simply outputting the position value, most encoders permit a certain degree of parametrization, such as selecting the positive direction of rotation, setting the position value to a reference value at a fixed physical position, and scaling the position value to an arbitrary resolution and a limited measuring range. This reduces the required complexity of the control program as well as the computational burden on the controller.

3.3.1 Single turn – ST

Measurement of the angle from 0° to 360° by means of a shaft represents the minimum functionality of a rotary encoder. The sensor system is based on optical or magnetic sampling of a measuring graduation on the encoder shaft.

The Model A58 series of encoders from EPC feature proprietary magnetic technology, which provides maximum precision and resolution for a single turn encoder.

3.3.2 Multi-turn – MT

A multi-turn encoder allows the number of revolutions to be recorded. This is achieved via a rotation counter. The EPC encoders include proprietary technology which ensures that the corresponding information is retained, even in a voltage-free state. This means that gearboxes, which require a comparatively large installation space and a correspondingly high degree of maintenance, are no longer needed.

3.3.3 Direction of rotation

The positive direction of rotation can be reversed by a simple two-part complement of the position value (invert every bit and add "1").

3.3.4 Preset

The desired position value can be assigned to the encoder at a specific physical position. This must be within the measuring range so that the position value is correlated with a physical reference position. For this purpose, the difference between the current position value and the desired value is calculated. The result is stored in non-volatile memory and added to the position value as an offset.

3.3.5 Scaling

To ensure that the position value exactly matches the variables to be physically measured, an adjustment can be carried out via the scaling parameters. The scalable parameters are “Measuring units per revolution (MUPR)” and “Total measuring range in measuring units (TMR).”

The scaling parameter “Measuring units per revolution (MUPR)” – increments per revolution – indicates the resolution of the position value per revolution (also: ST resolution). The value corresponds to 360°. That is, if a value of 3600 counts (Cts) is parametrized, the encoder outputs the position in 0.1° steps (see equation 2).

$$\text{Equation 1} \quad MUPR = ST = 3600 \text{ Cts}$$

$$\text{Equation 2} \quad \text{Angular steps} = \frac{\text{Angle of one revolution}}{MUPR} = \frac{360^\circ}{3600 \text{ Cts}} = 0.1^\circ / \text{Cts}$$

The scaling parameter “Total measuring range in measuring units (TMR)” – the maximum total measuring range of the position value (single turn and multi-turn multiplied) – indicates the total resolution of the encoder. When the position value reaches TMR -1, it jumps back to 0 and vice versa.

As a rule, the selected TMR parameter should be an integer multiple of the “Measuring units per revolution (MUPR)” (see equation 4), so that the zero point is always at the same position of the encoder shaft.

$$\text{Equation 3} \quad TMR = 36,000 \text{ Cts}$$

$$\text{Equation 4} \quad MT = \frac{TMR}{MUPR} = \frac{36,000 \text{ Cts}}{3600 \text{ Cts}} = 10$$

In exceptional cases, it is suitable that TMR is not an integer multiple of MUPR – for example, in a system in which a gear ratio ensures that the desired measured variable is moving 10% faster relative to the encoder shaft.

In this case, a setting of MUPR = 3960 Cts and TMR = 36,000 Cts would ensure that the faster (but not directly measurable) shaft can be measured with a resolution of 0.1° and over a range of 10 revolutions. Normally, the number of revolutions would be calculated by dividing the position value by MUPR. In this case, however, it must be divided by 3600 Cts, since the result would otherwise be the number of revolutions of the encoder shaft and not the faster shaft of the system.



- It should be noted that measurement errors will occur if the result of this formula is a decimal.

3.4 Connection assignments for EtherNet/IP encoders

3.4.1 RNB – bus cover

The string “RNB” in the order code identifies an encoder with a bus cover. The electrical connection is made on the bus cover via two M12 connectors and one M12 port. The connection assignments for the plugs and sockets are listed in Table 3.1.



Pin Assignment		Pin Assignment		Pin Assignment	
RNB		RNB		RNB	
					
Port (Port1)	M12, 4-pin, D-coded	Connector (Power)	M12, 4-pin, A-coded	Port (Port2)	M12, 4-pin, D-coded
Tx+	1	UB+	1	Tx+	1
Rx+	2	n. c.	2	Rx+	2
Tx-	3	UB-	3	Tx-	3
Rx-	4	n. c.	4	Rx-	4

Table 3.1: Connection assignment – RNB

3.5 LEDs and signaling

Four status LEDs on the bus cover signal the various encoder states, and support error diagnosis and troubleshooting in the field (see Table 3.2). The two link activity LEDs (L/A) light up or flash green when the encoder is connected to another Ethernet node (PLC, switch, additional field device, etc.) and data is being exchanged. The MOD LED shows the status of the encoder.

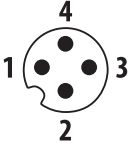
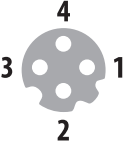

- ATTENTION! The STAT LED is lit during operation but is negligible for the network status of the encoder.

STAT LED bicolor	MOD LED bicolor	Meaning	Cause
○	○	No power	
● green solid	● green solid	Standby	The device has not yet been fully configured.
● green solid	● green solid	Operational	The device has been fully commissioned and data exchange is taking place.
● green solid	●/● green / red flashing	Self-test	The device is currently performing power up testing.
● green solid	● red flashing	Major recoverable fault	The device has detected a major recoverable fault. Please contact support.
● green solid	● red solid	Major unrecoverable fault	The device has detected a major unrecoverable fault. Please contact support.

Table 3.2: LED signals

Explanation of symbols: ○ LED off (no light) ●/● LED on/off (green/red light) ●/● LED flashing (flashing green/red light)

3.6 MAC address and IP address

EPC EtherNet/IP™ encoders have three MAC addresses. These always start with D4-90-E0-xx-xx-xx. The number depends on the number of ports on the integrated three-port switch. There is one MAC address each for Port1 and Port2, as well as one MAC address for the “internal port” to which the encoder itself is connected.

In the delivered state, the EtherNet/IP™ encoder has a static IP address of 192.168.1.127 and has the name “EPC-A58-IP”. If DHCP mode is desired, please refer to section 6.2. If you want to assign a static IP address, then you can define this in your project (e.g., Studio 5000) during project planning.

3.7 Programmable attributes

Adjustable parameters	<ul style="list-style-type: none"> Number of steps per revolution Number of revolutions Scaling Direction of rotation CAMs Gear ratio Preset Resolution Unit speed IP address Position Position limit Warning messages: "Frequency exceeded" <li style="padding-left: 20px;">"Position limits exceeded"
Objects (CIP objects)	<ul style="list-style-type: none"> Identity object Message router Assembly object Connection manager Position sensor object QoS object TCP/IP interface object Ethernet link object
EtherNet/IP™ features	<ul style="list-style-type: none"> DLR (Device Level Ring) possible QoS (Quality of Service) possible ACD (Address Conflict Detection) Multicast and unicast capability

4. EtherNet/IP

4.1 Functions overview

Functions	Meaning
Performance	Cycle time: <= 1 ms Ramp-up time: < 1 s
Webserver	Display and setting of parameters, as well as firmware updates
Process data	Cyclic up to 20 bytes
Profile	Encoder device profile: Device type 22h

Table 4.1: Functions

4.2 List of all classes

Code	Class	Instance
01h	Identity	1
02h	Message router	1
04h	Assembly	6
06h	Connection manager	1
23h	Position sensor object	1
47h	Device Level Ring	1
48h	QoS	1
F5h	TCP/IP interface	1
F6h	Ethernet link	3

Table 4.2: List of all classes

4.3 Process and configuration data

In an EtherNet/IP™ network, the process data can be read out either via the assembly object or by “explicit messaging” of the “position sensor object.”

The assemblies are predefined and fixed by the manufacturer and/or the specification. They cannot be changed by the user, so they contain only selected cyclic process data. With the “position sensor object” it is possible to access all process data acyclically.

Process data overview (assemblies)

The following table lists the available assemblies. You can find a detailed description in sections 4.3.2 – 4.3.7.

Instance Number	Meaning
1	Position
2	Position + State
3	Position + Velocity
100	Position + Velocity + Position state + CAM state + Status
101	Position64 + Velocity + Position state + CAM state + Status
101 + 110	101: Position64 + Velocity + Position state + CAM state + Status Config (110): Preset + MUPR + TMR + Gear ratio multiplier + Gear ration divisor + Velocity format + Direction counting toggle + Scaling enable + Preset execute

Table 4.3: Process data overview

Process data assembly 1

This assembly contains the position value. It also has a width of 32 bits. The position value is unsigned.

Instance	Signal									Description
	Byte	Bit: 0	Bit: 1	Bit: 2	Bit: 3	Bit: 4	Bit: 5	Bit: 6	Bit: 7	
1	0	Position LSB								Position value (scaled). The position value calculation is influenced by the following functions, among others: MUPR, TMR, scaling function, offset, preset, gear ratio if applicable.
	1	Position								
	2	Position								
	3	Position MSB								

Table 4.4: Assembly 1

Process data assembly 2

This assembly contains the position value and a status display. It also has a width of 40 bits. The position value is unsigned.

Instance	Signal									Description
	Byte	Bit: 0	Bit: 1	Bit: 2	Bit: 3	Bit: 4	Bit: 5	Bit: 6	Bit: 7	
2	0	Position LSB								Position value (scaled). The position value calculation is influenced by the following functions, among others: MUPR, TMR, scaling function, offset, preset, gear ratio if applicable.
	1	Position								
	2	Position								
	3	Position MSB								
	4	Alarm flag	Warning flag	x	x	x	x	x	x	0 if there are no warning or alarms, otherwise 1.

Table 4.5: Assembly 2

Process data assembly 3

This assembly contains the position value and the velocity. It also has a width of 64 bits. The position value is unsigned, but the velocity value is signed.

Instance	Signal									Description
	Byte	Bit: 0	Bit: 1	Bit: 2	Bit: 3	Bit: 4	Bit: 5	Bit: 6	Bit: 7	
3	0	Position LSB							Position value (scaled). The position value calculation is influenced by the following functions, among others: MUPR, TMR, scaling function, offset, preset, gear ratio if applicable.	
	1	Position								
	2	Position								
	3	Position MSB								
	4	Velocity LSB							Velocity value. The velocity value is influenced by the following functions, among others: velocity format, velocity resolution.	
	5	Velocity								
	6	Velocity								
	7	Velocity MSB								

Table 4.6: Assembly 3

Process data assembly 100

This assembly contains the position value, the speed, a position status register, a CAM status register, and a status display. It also has a width of 88 bits. The position value is not signed, but the velocity value is.

Instance	Signal									Description
	Byte	Bit: 0	Bit: 1	Bit: 2	Bit: 3	Bit: 4	Bit: 5	Bit: 6	Bit: 7	
100	0	Position LSB							Position value (scaled). The position value calculation is influenced by the following functions, among others: MUPR, TMR, scaling function, offset, preset, gear ratio if applicable.	
	1	Position								
	2	Position								
	3	Position MSB								
	4	Velocity LSB							Velocity value. The velocity value is influenced by the following functions, among others: velocity format, velocity resolution.	
	5	Velocity								
	6	Velocity								
	7	Velocity MSB								
	8	Position state register							Software end positions switch. 0 if within the defined limit range, otherwise 1.	
	9	CAM state register							Software camshafts. 0 if within the defined limit range, otherwise 1.	
10	Status							See Table 4.8		

Table 4.7: Assembly 100

Process data assembly 101

This assembly contains the position value (64-bit), the speed, a position status register, a CAM state register, and a status display. It also has a width of 128 bits. The position value is not signed, but the velocity value is.

Instance	Signal									Description	
	Byte	Bit: 0	Bit: 1	Bit: 2	Bit: 3	Bit: 4	Bit: 5	Bit: 6	Bit: 7		
101	0	Position64 LSB									Position value (scaled). The position value calculation is influenced by the following functions, among others: MUPR, TMR, scaling function, offset, preset, gear ratio if applicable.
	1	Position64									
	2	Position64									
	3	Position64									
	4	Position64									
	5	Position64									
	6	Position64									
	7	Position64 MSB									
	8	Velocity LSB									Velocity value. The velocity value is influenced by the following functions, among others: velocity format, velocity resolution.
	9	Velocity									
	10	Velocity									
	11	Velocity MSB									
	12	Position state register									Software end positions switch. 0 if within the defined limit range, otherwise 1.
	13	CAM state register									Software camshafts. 0 if within the defined limit range, otherwise 1.
14	Status									Signals the status of the encoder: 0000: Self-test 0001: FW update in progress 0010: Min. one connection error 0011: No connection 0100: Configuration error 0101: Major fault 0110: Min. one connection in run 0111: Min. one connection, all in idle 1000: Reserved 1001: Reserved 1111: Sensor error	

Table 4.8: Assembly 101

Configuration assembly 110

This assembly contains the preset, the MUPR, the TMR, the gear ratio, the speed format and in the last byte the direction change, the scaling, and the preset (execute). It also has a width of 216 bits.

Instance	Signal									Description
	Byte	Bit: 0	Bit: 1	Bit: 2	Bit: 3	Bit: 4	Bit: 5	Bit: 6	Bit: 7	
110	0	Preset LSB								Preset The preset sets the position value to a fixed value. Will only be executed if preset execute = 1.
	1	Preset								
	2	Preset								
	3	Preset								
	4	Preset								
	5	Preset								
	6	Preset								
	7	Preset MSB								Measuring units per revolution The MUPR defines how many increments one revolution of 360° of the encoder shaft is resolved.
	8	MUPR LSB								
	9	MUPR								
	10	MUPR								
	11	MUPR MSB								Total measuring range The TMR defines the total measuring range of the encoder, i.e., after how many increments the position value rolls over to 0.
	12	TMR LSB								
	13	TMR								
	14	TMR								
	15	TMR								
	16	TMR								
	17	TMR								
	18	TMR								
	19	TMR MSB								Here the size of the encoder gear is set.
	20	Gear ratio multiplier LSB								
	21	Gear ratio multiplier MSB								
	22	Gear ratio divisor LSB								Here the size of the main gear is set.
	23	Gear ratio divisor MSB								
	24	Velocity format LSB								Sets the format of the position value. 1F04h: Counts per second (default) 1F05h: Counts per ms 1F07h: Counts per minute 1F0Fh: Revolutions per minute
25	Velocity format MSB									
26	Direction counting toggle	Scaling enabled	Preset execute	x	x	x	x	x	Bit 0: Direction counting toggle defines the counting direction of the position value. Bit 1: Scaling enable determines whether scaling is on or off. Bit 2: Preset execute defines whether a preset is executed or not.	

Table 4.9: Configuration assembly 110

4.4 Class attributes

Here you can find a detailed listing of the classes 01h and 23h.

Identity object 01h

The identity object provides general information about the device such as identification, status, etc.

Attribute ID	Name	Data type	Access	Description
1	Vendor ID	UINT	R	Specifies the vendor ID of the manufacturer.
2	Device type	UINT	R	Specifies the type of device.
3	Product code	UINT	R	Used to identify the device to the manufacturer.
4	Revision	USINT	R	Revision number of the device
5	Status	WORD	R	Represents the current status of the device. 0000b: Self-test 0001b: FW update in progress 0010b: Min. one connection error 0011b: No connection 0100b: Configuration error 0101b: Major fault 0110b: Min. one connection in run 0111b: Min. one connection, all in idle 1000b: Reserved 1001b: Reserved 1111b: Sensor fault
6	Serial number	UDINT	R	The serial number of the device.
7	Product name	STRING	R	Product name as ASCII string.
8	State	USINT	R	Current state of the device. 0: Non-existent 1: Self-test 2: Standby 3: Ready for operation 4: Major recoverable fault 5: Major unrecoverable fault

Table 4.10: Identity object

Position sensor object 23h

The position sensor object provides all process data of the encoder.

Attribute ID	Name	Data Type	Access	Description
1	Number of attributes	USINT	R	Represents the number of attributes implemented in the position sensor object.
2	Attribute list	Array of USINT	R	Outputs all implemented attributes as a list.
3	Position value unsigned	UDINT	R	Indicates the position value of the encoder (see Table 4.4: Assembly 1).
11	Position sensor type	UINT	R	Indicates which type the position sensor has. 01h = Absolute single turn encoder 02h = Absolute multi-turn encoder
12	Direction counting toggle	BOOL	RW	Defines the counting direction of the position value with view to the encoder shaft. 0 = positive counting direction of the position value with clockwise shaft rotation. 1 = positive counting direction with counter clockwise shaft rotation.
14	Scaling function control	BOOL	RW	The scaling of the encoder can be switched on or off here. If 0: Position value (attr. 3) = Physical resolution of the encoder. If 1: Position value (attr. 3) = (Physical resolution of the encoder) * (MUPR (attr. 16) / Physical resolution span (attr. 42))
16	Measuring units per span	UDINT	RW	See Table 4.9
17	Total measuring range in measuring units	UDINT	RW	See Table 4.9
19	Preset value	UDINT	RW	The preset value is subject to scaling; it can be reset again and again. Default: 0 If the preset is executed, then the following applies to the offset: Offset value (attr. 51) = Preset value - Position value
21	Position state register	USINT	R	The position state register serves as a software defined limit switch. Bit 0 = 1 Out of range Bit 1 = 1 Range overflow Bit 2 = 1 Range underflow
22	Position low limit	DINT	RW	Lower limit of the end position. Is compared with the position value. If the value falls below the limit, the status can be read out via attribute 21.
23	Position high limit	DINT	RW	Upper limit of the end position. Is compared with the position value; if exceeded, the status can be read out via attribute 21.
24	Velocity value	DINT	R	See Table 4.6

Attribute ID	Name	Data Type	Access	Description
25	Velocity format	ENGUINT	RW	See Table 4.6 and Table 4.9
26	Velocity resolution	UDINT	RW	The resolution of the velocity value is defined in steps of 0.01 mm/s.
41	Operating status	USINT	R	Indicates the operating status of the encoder: Bit 0: Direction False (0) = Increasing True (1) = Decreasing Bit 1: Scaling False (0) = Off True (1) = ON
42	Physical resolution span	UDINT	R	The maximum number of steps per revolution is shown here. = 10000h
43	Number of spans	UINT	R	Specifies how many revolutions can be measured. ST = 1 MT = FFFFh
44	Alarms	WORD	R	An alarm is set when a malfunction bit is set to true. The alarm remains active until it is cleared, and the device is able to operate correctly again. Bit 0: Position error Bit 1: Diagnostic error Bit 2...11: Reserved Bit 12...15: Manufacturer-specific
45	Supported alarms	WORD	R	Contains the information about the supported alarms of the device. Bit 0: Position error Bit 1: Diagnostic error Bit 2...11: Reserved Bit 12...15: Manufacturer-specific
46	Alarm flag	BOOL	R	The flag indicates whether an alarm error has occurred. It corresponds to a logical OR of all alarm bits of attribute 44.
47	Warnings	WORD	R	The warnings indicate when certain parameters of the device are not adhered to or when limit values are exceeded. All warnings are deleted as soon as the parameters are back in the normal range. Bit 0: Frequency exceeded Bit 10: Position limits exceeded Bit 11.. 12: Reserved Bit 13...15: Manufacturer-specific
48	Supported warnings	WORD	R	This attribute contains information about the supported warnings of the device. Bit 0: Frequency exceeded Bit 10: Position limits exceeded Bit 11...12: Reserved Bit 13...15: Manufacturer-specific

Attribute ID	Name	Data Type	Access	Description
49	Warning flag	BOOL	R	This flag signals when a warning error has occurred. It corresponds to a logical OR of all alarm bits of attribute 47.
50	Operating time	UDINT	R	Incremented at power up. Subsequently, the value increases by 1 every 6 minutes.
51	Offset value	DINT	R	The preset function shifts part of the position value to the offset. The offset value is automatically stored in the device and can be used for diagnostics. Offset value = Preset value - Position value
100	Position 64-bit	ULINT	R	See Table 4.8
101	Raw position	ULINT	R	Raw position value of the encoder.
102	TMR 64-bit	ULINT	RW	See Table 4.9
103	Preset 64-bit	LINT	RW	See Table 4.9
104	Offset 64-bit	LINT	R	See attribute 51
105	Hysteresis position	SINT	RW	Size of the hysteresis for the position value. Value range: 0...255 Default: 04h
106	Filter position	SINT	RW	Number of average values for the position value. Value range: 0...255
107	Gear multiplier	WORD	RW	The two parameters, gear ratio numerator and denominator, can be used to adjust the position value to take into account an existing gear.
108	Gear divisor	WORD	RW	<p>The total resolution for this function is limited to 20 bits (max. 1,048,576 steps).</p> <p>The revolution resolution has no relevance for this function, the 16-bit raw resolution is always used.</p> <p>Example rotary table: Gear encoder: 12 teeth Driven rotary table: 250 teeth</p> <p>One revolution of the rotary table should be mapped to 100,000 steps.</p> <p>If the driven rotary table rotates once, then the encoder shaft rotates by 250/12, i.e., 20.8333 times.</p> <p>The following setting must be selected here: Gear ratio numerator: 12 Gear ratio denominator: 250 Total resolution: 100,000</p>
109	Position low limit 64-bit	LINT	RW	See attribute 22
110	Position high limit 64-bit	LINT	RW	See attribute 23
111	Frequency limit	WORD	RW	The frequency of rotation can be set via the frequency limit. This influences attribute 47 (warnings).
112	Sensor error	WORD	R	

Attribute ID	Name	Data Type	Access	Description
113	CAM state register	USINT	R	The CAM state register serves for the representation of the cam switching states in dependence on the position of the encoder shaft. For this purpose, the value of the register must be broken down in binary notation (see below). Each bit of the octet shows the status of a certain switching position. See section 4.4.2.1.
114	CAM enable register	USINT	RW	Each cam switch position of the CAM channel in the encoder must be "switched on" individually for use. The "switching on" of the individual CAM works by writing the appropriate value into the attribute. The correct value can be found by setting the bit to 1 in binary notation for each cam switch position that is to be active. See section 4.4.2.2.
115	CAM polarity register	USINT	RW	The CAM polarity register can be used to change the polarities of each cam switch position in the CAM channel. By default, the polarity is set so that all cam positions "jump" to high (= 1b) at position values in their limits. By changing the individual bits, the individual polarities of the cam positions can be changed. Thus, for a value of 13h (= 0110 0100b), CAM 3, CAM 6, and CAM 7 are inverted when position value is within limits. See section 4.4.2.3.
116	CAM low limits 1	LINT	RW	The CAM low limit defines the lower switching point of a cam switch position. Each individual cam position has its own CAM low limit attribute. See section 4.4.2.4.
117	CAM low limits 2	LINT	RW	See above
118	CAM low limits 3	LINT	RW	See above
119	CAM low limits 4	LINT	RW	See above
120	CAM low limits 5	LINT	RW	See above
121	CAM low limits 6	LINT	RW	See above
122	CAM low limits 7	LINT	RW	See above
123	CAM low limits 8	LINT	RW	See above
124	CAM high limits 1	LINT	RW	The CAM high limit defines the upper switching point of a cam switch position. Each individual cam position has its own high limit attribute. See section 4.4.2.5.
125	CAM high limits 2	LINT	RW	See above
126	CAM high limits 3	LINT	RW	See above
127	CAM high limits 4	LINT	RW	See above
128	CAM high limits 5	LINT	RW	See above
129	CAM high limits 6	LINT	RW	See above
130	CAM high limits 7	LINT	RW	See above

Attribute ID	Name	Data Type	Access	Description
131	CAM high limits 8	LINT	RW	See above
132	CAM hysteresis 1	UINT	RW	The width of the hysteresis of the switchover points is defined via the CAM hysteresis. For each individual cam switch position a separate CAM hysteresis can be set. See section 4.4.2.6.
133	CAM hysteresis 2	UINT	RW	See above
134	CAM hysteresis 3	UINT	RW	See above
135	CAM hysteresis 4	UINT	RW	See above
136	CAM hysteresis 5	UINT	RW	See above
137	CAM hysteresis 6	UINT	RW	See above
138	CAM hysteresis 7	UINT	RW	See above
139	CAM hysteresis 8	UINT	RW	See above
140	Preset execute	BOOL	RW	If the preset value has been set once in attribute 19, then you can execute the preset again via attribute 140 "preset execute" without having to assign a new value. The value automatically resets to 0.

Table 4.11: Position sensor object

4.4.1.1 113d – CAM state register

The CAM state register (attribute 113d) is used to represent the cam switching states depending on the position of the encoder shaft. For this purpose, the value of the register must be broken down in binary notation (see below). Each bit of the octet from attribute 113 shows the status of a specific switching position.

The following example shows a CAM state register with the value 89h:

Position	7 (MSB)	6	5	4	3	2	1	0 (LSB)
Type	CAM 8	CAM 7	CAM 6	CAM 5	CAM 4	CAM 3	CAM 2	CAM 1
Value	1	0	0	0	1	0	0	1
Logic	High	Low	Low	Low	High	Low	Low	High

Table 4.12: CAM state register

As can be seen above, the value 89h defines that the cam positions CAM 1, CAM 4, and CAM 8 are high and the remaining cams are low. If the shaft continues to rotate, it could happen, for example, that CAM 4 finally becomes low as well. Then the value of the CAM state register = 81h:

Position	7 (MSB)	6	5	4	3	2	1	0 (LSB)
Type	CAM 8	CAM 7	CAM 6	CAM 5	CAM 4	CAM 3	CAM 2	CAM 1
Value	1	0	0	0	0	0	0	1
Logic	High	Low	Low	Low	Low	Low	Low	High

Table 4.13: CAM state register

By switching each CAM independently, 256 different states can thus be generated within one attribute, which can be used to control machines.

4.4.1.2 114d – CAM enable register

Each cam position of the CAM channel in the encoder must be “switched on” individually for use. The “switching on” of the individual CAM works by writing the appropriate value into attribute 114d. The correct value is to be found by setting the bit to 1 in binary notation for each cam switch position that is to be active. For example, if only CAM 2, CAM 4, and CAM 7 are to be active, the result after binary notation is:

Position	7 (MSB)	6	5	4	3	2	1	0 (LSB)
Type	CAM 8	CAM 7	CAM 6	CAM 5	CAM 4	CAM 3	CAM 2	CAM 1
Value	0	1	0	0	1	0	1	0

Table 4.14: CAM enable register

This corresponds to the value 4Ah.

4.4.1.3 115d – CAM polarity register

The CAM polarity register in attribute 115 can be used to change the polarities of each cam switch position in the CAM channel. By default, the polarity is set so that all cam positions “jump” to high (= 1b) at position values in their limits (default = 000000b = 00h). By changing the individual bits, the individual polarities of the cam positions can be changed. Thus, at a value of 13h (= 00010011b) CAM 1, CAM 2, and CAM 5 are inverted (bit = 0b (low), if position value within the limits).

Position	7 (MSB)	6	5	4	3	2	1	0 (LSB)
Type	CAM 8	CAM 7	CAM 6	CAM 5	CAM 4	CAM 3	CAM 2	CAM 1
Value	0	0	0	1	0	0	1	1
Logic	Default	Default	Default	Inverted	Default	Default	Inverted	Inverted

Table 4.15: CAM polarity register

4.4.1.4 116d...123d – CAM1...CAM8 low limit

The CAM low limit defines the lower switching point of a cam switch position. Each individual cam switch position (CAM1...CAM8) has its own CAM low limit attribute (see attributes 116d – 123d).

4.4.1.5 124d...131d – CAM1...CAM8 high limit

The CAM high limit defines the upper switching point of a cam switch position. Each individual cam switch position (CAM1...CAM8) has its own CAM high limit object (see attributes 124d – 131d).

4.4.1.6 132d...139d – CAM1...CAM8 hysteresis

The width of the hysteresis of the switch-over points is defined via the CAM hysteresis. For each individual cam switch position (CAM1...CAM8) a separate CAM hysteresis can be set (see attributes 132d – 139d).

5. Webserver

5.1 General

The EtherNet/IP™ encoders have a web server where you can view or set some information and configurations. To access the web server, call up its IP address using a browser of your choice (Microsoft Edge, Firefox, etc.). To do this, connect the encoder to your computer via an Ethernet cable (M12 connector on the encoder and RJ45 connector on the PC). Make sure that your PC is in the same IP address range as the encoder.



- Example configuration:
IP address of the encoder: 192.168.1.127
IP address of the PC: 192.168.1.100
Subnet address of the PC: 255.255.255.0

Once you have done this, the start page (Information – Overview) of the encoder opens.

In the following subchapters we will show you the different views of the web server and explain the possible functions.

5.2 Overview

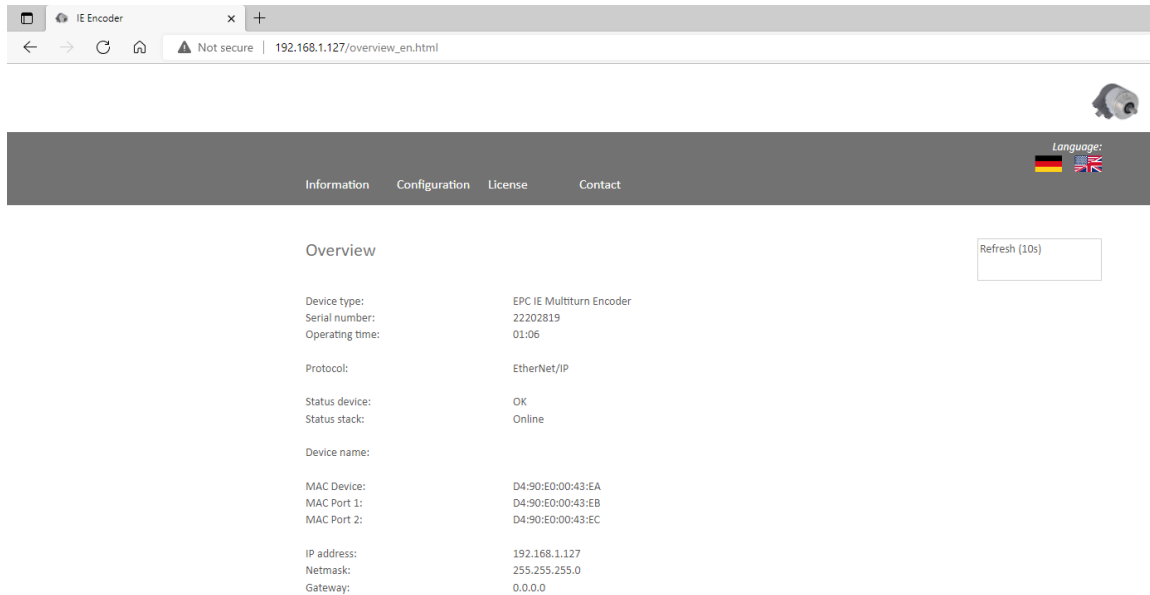

Figure 5.1: Overview

In the overview you will find the following information:

- Device type: designation of the encoder
- Serial number: device number of the encoder
- Operating time in hours: number of hours in running operation
- Protocol: EtherNet/IP™
- Device status: on or off state
- Stack status: connected or offline
- Device name: EPC-A58-IP
- MAC device: MAC address of the encoder
- MAC port 1: MAC address of Ethernet port 1
- MAC port 2: MAC address of Ethernet port 2
- IP address: IP address of your EtherNet/IP™ encoder
- Netmask: subnet mask of your EtherNet/IP™ encoder
- Gateway: gateway of your EtherNet/IP™ encoder

The refresh rate of the web page is fixed at 10 seconds and cannot be changed. You can tell that the data is being updated by the message “Refreshing data” at the top right of the field where the refresh time is displayed.

You can switch the language of the web server after the webpage has loaded.

Versions

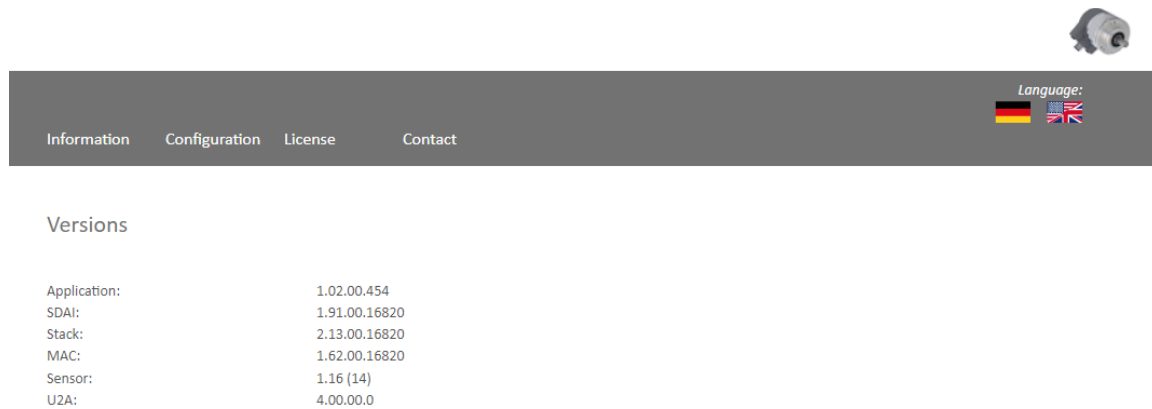

Application:	1.02.00.454
SDAI:	1.91.00.16820
Stack:	2.13.00.16820
MAC:	1.62.00.16820
Sensor:	1.16 (14)
U2A:	4.00.00.0

Figure 5.2: Versions

Here you can find the information of each version status like:

- Application
- SDAI
- Stack
- MAC
- Sensor
- U2A

5.3 Configuration

Network



Figure 5.3: Network

Here you can change the device name, IP address, network mask, and gateway.



- Please make sure that you only change the data when the encoder outputs are not being monitored.

Encoder



Language:



[Information](#) [Configuration](#) [License](#) [Contact](#)

Encoder

Current values

Raw position value:	-590043
Scaled position value:	590043
Offset value:	0
Speed value:	0

Setting

Code sequence:	Clockwise
Scaling enabled:	No
Measuring units per revolution:	65536
Total measuring range:	576460752303423500
Gear ratio:	1 / 1
Speed calculation source:	Scaled Position
Integration time:	1000 ms
Speed factor:	1 / 1

Figure 5.4: Encoder

Here you can check the following parameterized values of the encoder:

- Raw position value
- Scaled position value
- Offset
- Velocity value
- Code sequence (direction of rotation)
- Scaling enabled (yes/no)
- Measuring units per revolution (MUPR)
- Total measuring range (TMR)
- Gear ratio
- Speed calculation source
- Speed factor

5.3.1 Firmware update

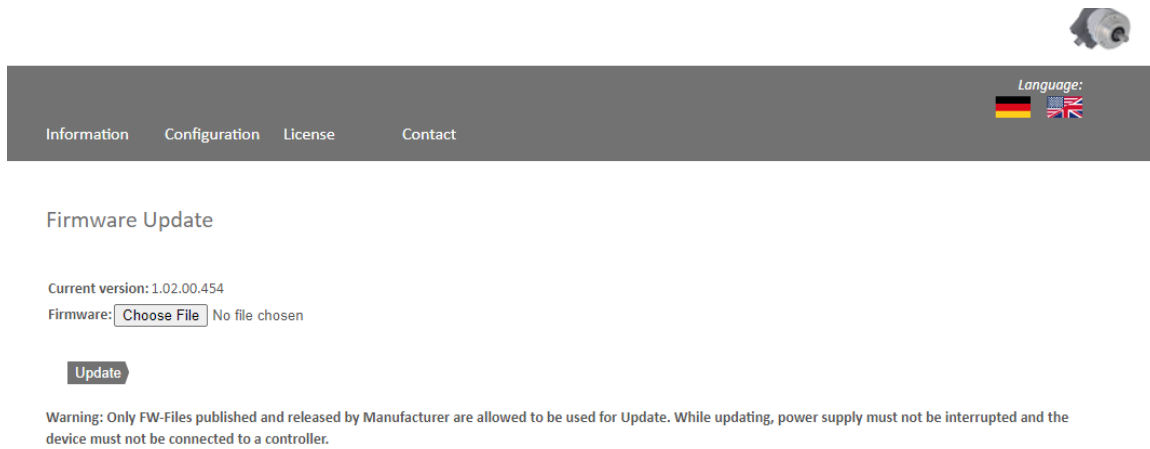

Figure 5.5: Firmware update

The current firmware version of the encoder is displayed. If a new firmware version is available, you can update the encoder's firmware here.

	<ul style="list-style-type: none">• Please make sure that you only update the firmware when the encoder outputs are not being monitored.
--	--

To update the firmware of the encoder, choose the correct .bin file by clicking the “browse...” button (see Figure 5.6: Firmware update – choose file).

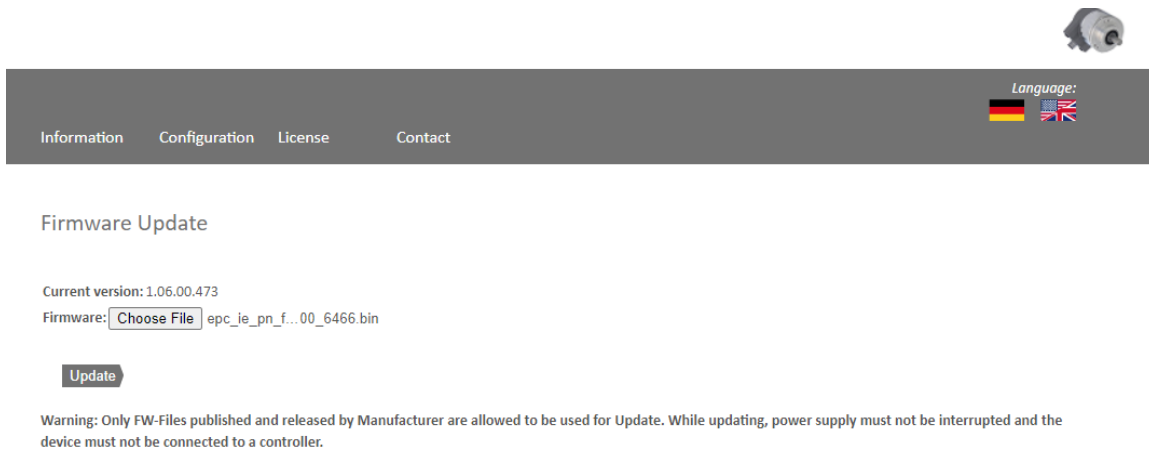

Figure 5.6: Firmware update – choose file

After you have chosen the correct file, click the “update” button to start the firmware update. An animated icon will appear with the additional text “transferring file” (see Figure 5.7).

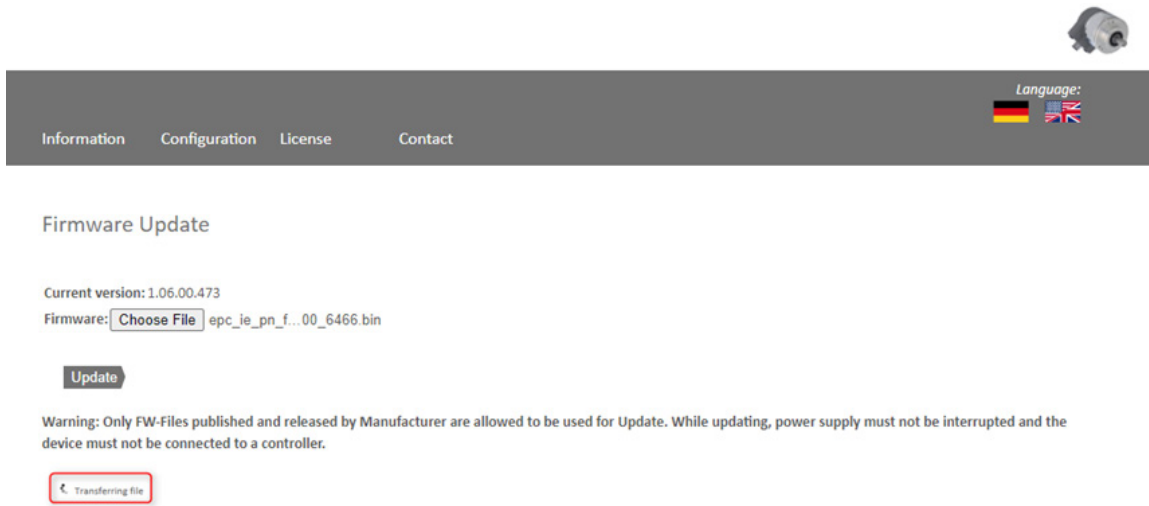

Figure 5.7: Firmware update – transferring file

After the firmware update has successfully finished, you will see a “successful” message as shown in Figure 5.8. Perform a power reset and check under “information -> versions” if the new firmware version is shown.

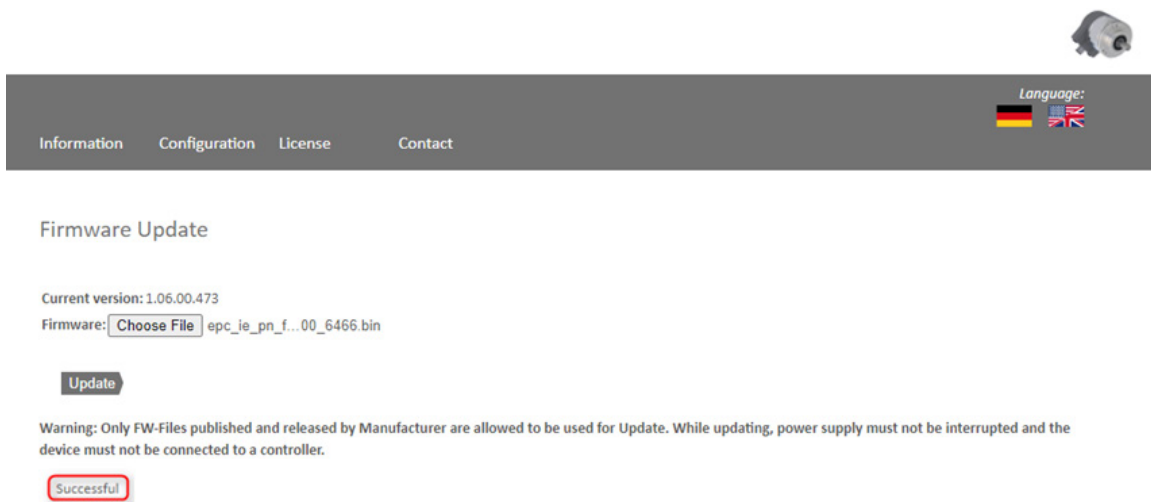

Figure 5.8: Firmware update – successful

In case of a failure during the firmware update process (see Figure 5.9) please double check that you chose the correct firmware file. Do a power reset and repeat the whole firmware update process. In case of a power loss during the update, the encoder may not respond to any request anymore. If this happens, please contact our support team.

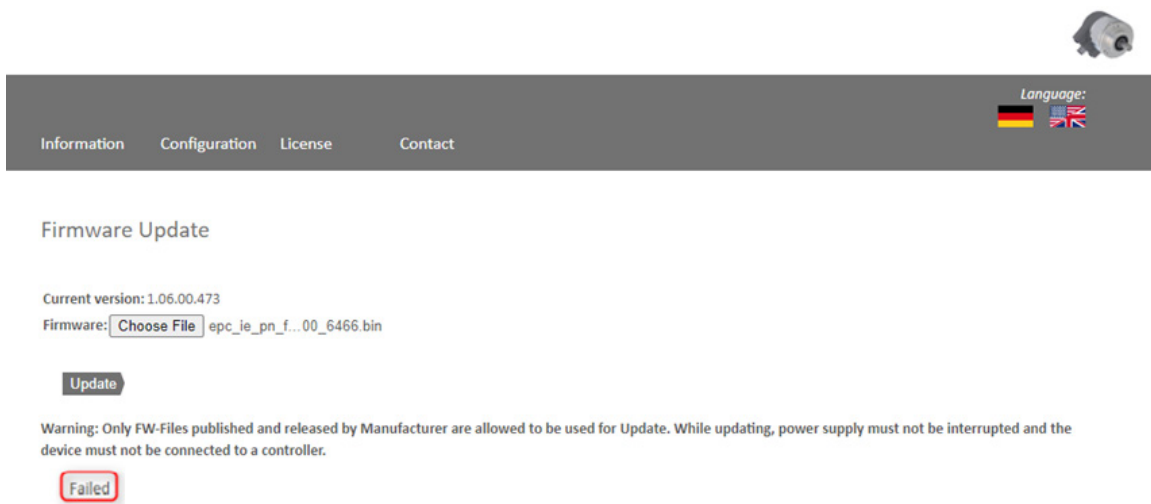

Figure 5.9: Firmware update – failed

5.4 License information



Information Configuration **License** Contact

Language:  

License Information

ATTENTION safety instructions:

For use by technically qualified personnel only. Read the manual before using the product. The products are only designed and produced for use in industrial environments and NOT for use in safety related applications.

Copyright, EPC, USA

Packages under a modified version of the GPL

The firmware uses the following packages with modified GPL license

eCos Operating System

These components are used on the operating system layer of the firmware. The protocol stacks does not use code under GPL license.

Download the source code of these packages from [here](#).

Figure 5.10: License information

This view contains the current safety instructions as well as software packages containing firmware. You can download the source code of these packages using the link on this website.

5.5 Contact



Information
Configuration
License
Contact

Language:

Contact

Product Information

For general information about the product please contact:

Phone:	+1 208 263 8541
Fax:	+1 208 263 0541
Email:	sales@encoder.com
www:	www.encoder.com

Technical Support

If you need technical support please contact:

Phone:	+1 208 263 8541
Fax:	+1 208 263 0541
Email:	support@encoder.com
Other countries:	sales@encoder.com

Figure 5.11: Contact information

Contact information for additional product information and technical support is listed here.

6. Commissioning

6.1 General

This chapter shows a configuration example of the EPC Model A58 EtherNet/IP™ encoder. The example is carried out with the Rockwell Studio 5000 software (Ver. 32.00). The device will have the static IP address 192.168.1.127 by default. DHCP mode can be activated using the method outlined below if desired.

6.2 Activating DHCP mode

If you want to reset the device to DHCP mode, start the tool “BootP DHCP EtherNet/IP™ commissioning tool” which was installed during the Studio 5000 installation. On a free Ethernet network card, you should set a static IP address. A setting in the address range 192.168.1.XXX is recommended, because the default IP address of the encoder is also in this address range (192.168.1.127).

Now select the previously configured network card. After a short waiting time the encoder will appear in the upper window.

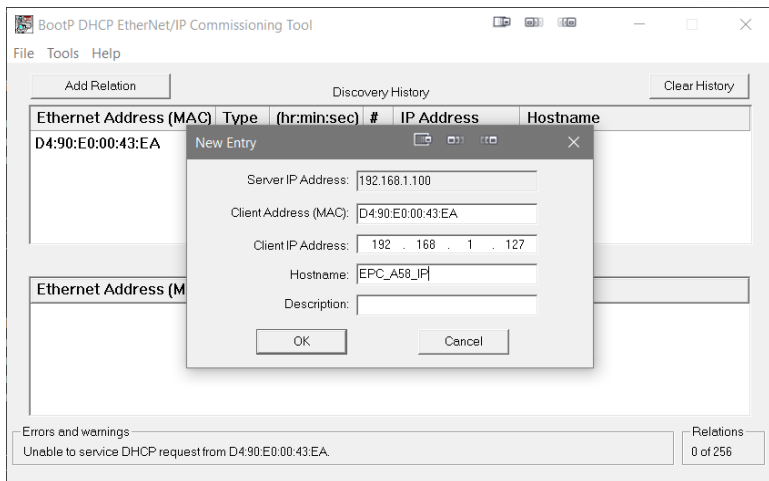

Figure 6.1: Set MAC and IP address

After you have added the device, select it and click on “enable BOOTP/DHCP.” A confirmation is now displayed in the “errors and warnings” window. Your device is in DHCP mode.

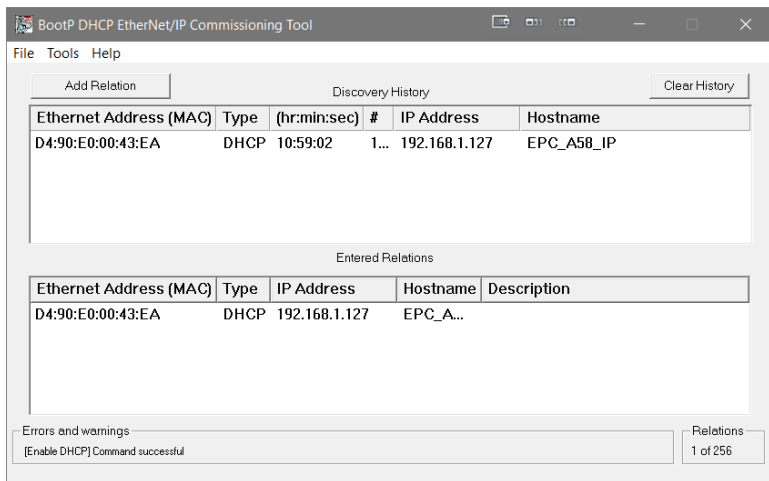

Figure 6.2: DHCP activated

6.3 Deactivating DHCP mode and assigning an IP address

If you have not done so yet, install Studio 5000 with all additional components.

On a free Ethernet network card, you should set a static IP address. A setting in the address range 192.168.1.XXX is recommended, because the default IP address of the encoder is also in this address range (192.168.1.127).

Once you have done this, start the tool “BootP DHCP EtherNet/IP™ commissioning tool,” which was installed during the Studio

5000 installation. Now select the previously configured network card. After a short waiting time the encoder will appear in the upper window.



- Firewalls may prevent BootP DHCP from finding the connected encoder. If the encoder does not appear, try disabling the firewall.

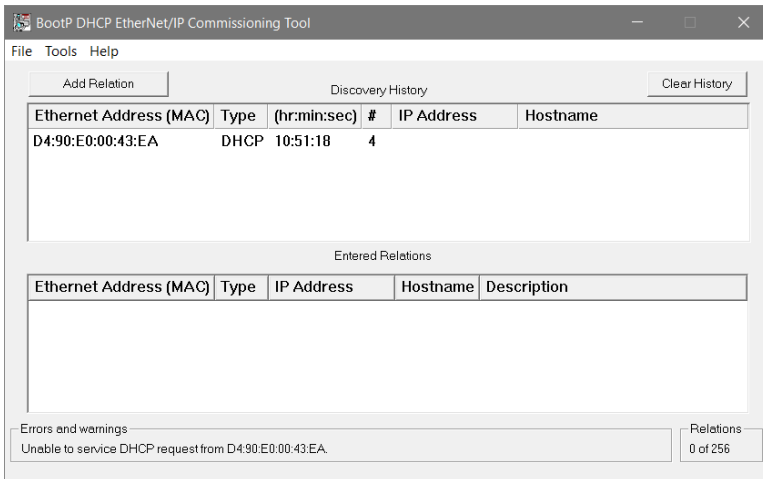

Figure 6.3: BootP DHCP tool



- Verify that your network card is configured correctly under "tools -> network settings."

Now click with the right mouse button on the device and select "add relation." A new window will appear where you can assign a static IP address and a name for the device.

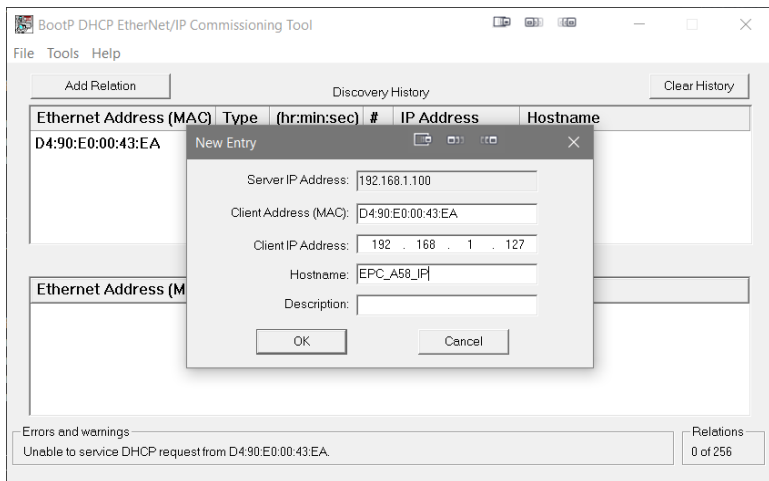

Figure 6.4: Set IP address and device name

If the IP address was assigned successfully, a confirmation will appear in the errors and warnings window.

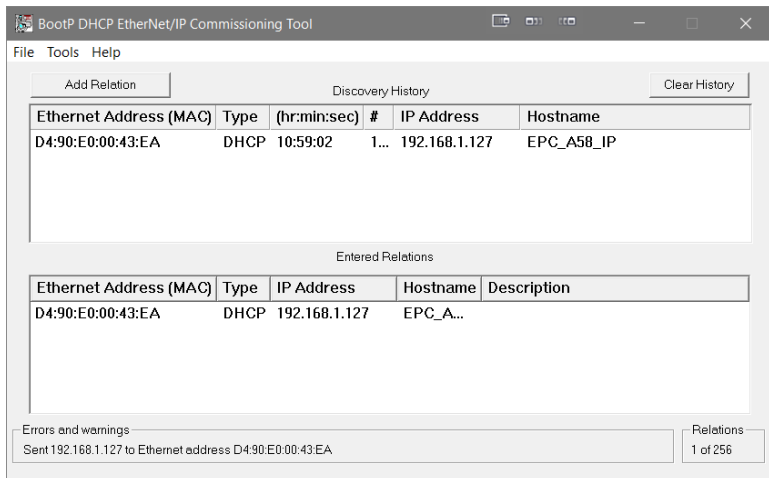

Figure 6.5: IP address and device name successfully set

Then select your device in the lower window and click on “disable BOOTP/DHCP.” If the command was executed successfully, a confirmation will again appear under “Errors and warnings.”

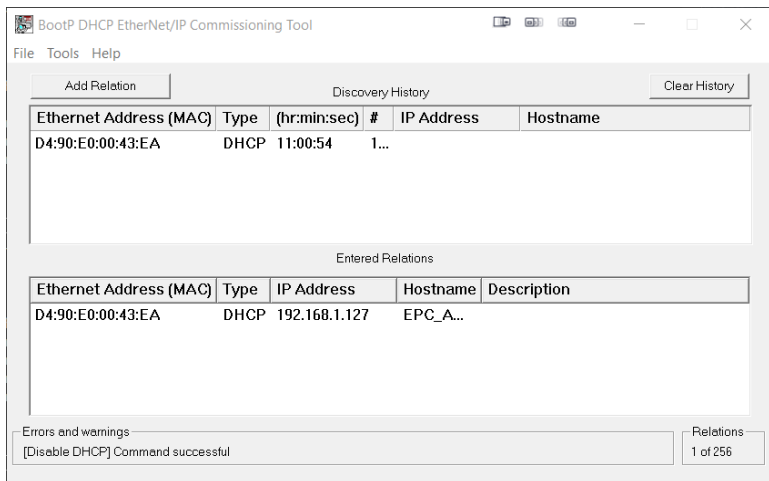

Figure 6.6: DHCP deactivated

Now use a browser of your choice and check if the web server is reachable.

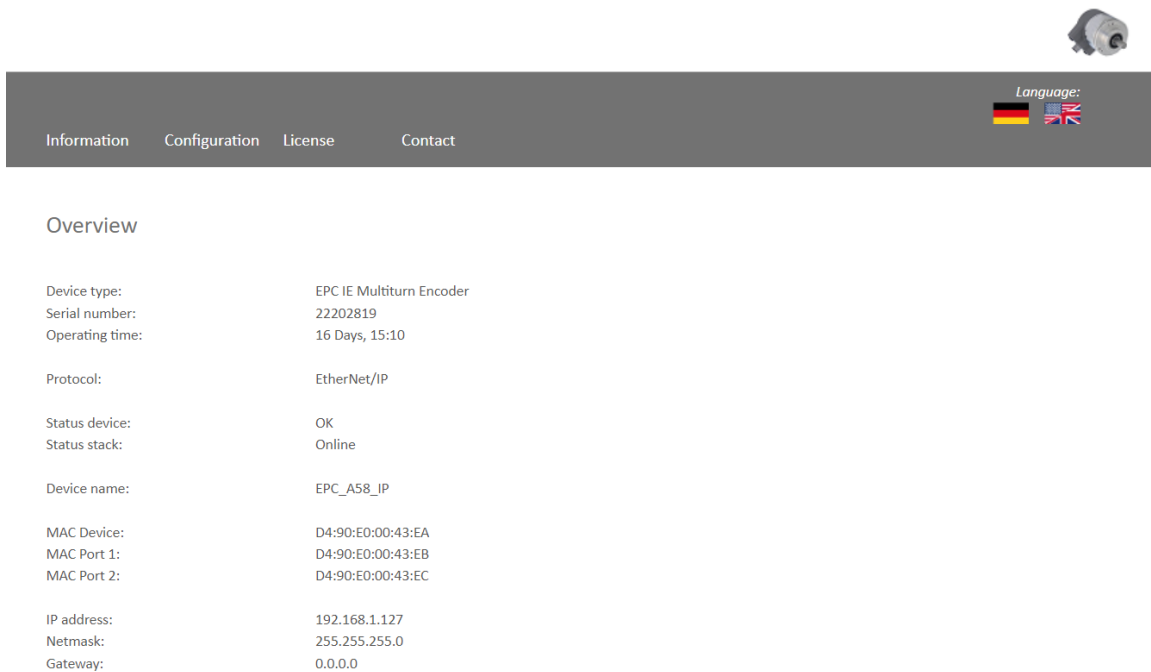

Figure 6.7: Webserver available

6.4 Integration into a Studio 5000 project

Connect the device to your controller. Supply voltage to the encoder.



- Here it is assumed that you have already correctly configured your controller and the relevant network. If you have not yet done so, first read the relevant manual and carry out commissioning accordingly.

To include the encoder in Studio 5000, start it and open the desired project.

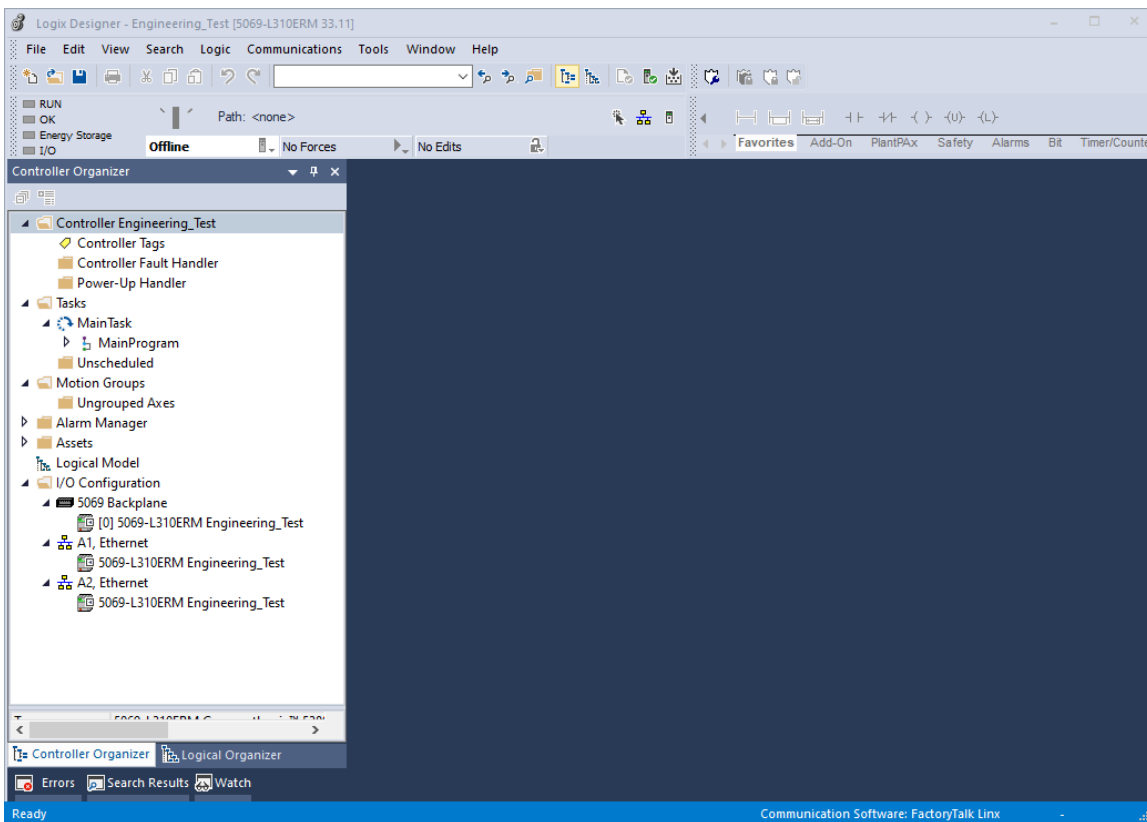

Figure 6.8: Main menu

You should now find yourself in the window shown in Figure 6.8. Install the EDS file. A link to download the EDS file can be found on the product page for your encoder model at encoder.com. To install the EDS file, open the “tools” tab and select the “EDS hardware installation tool” menu.

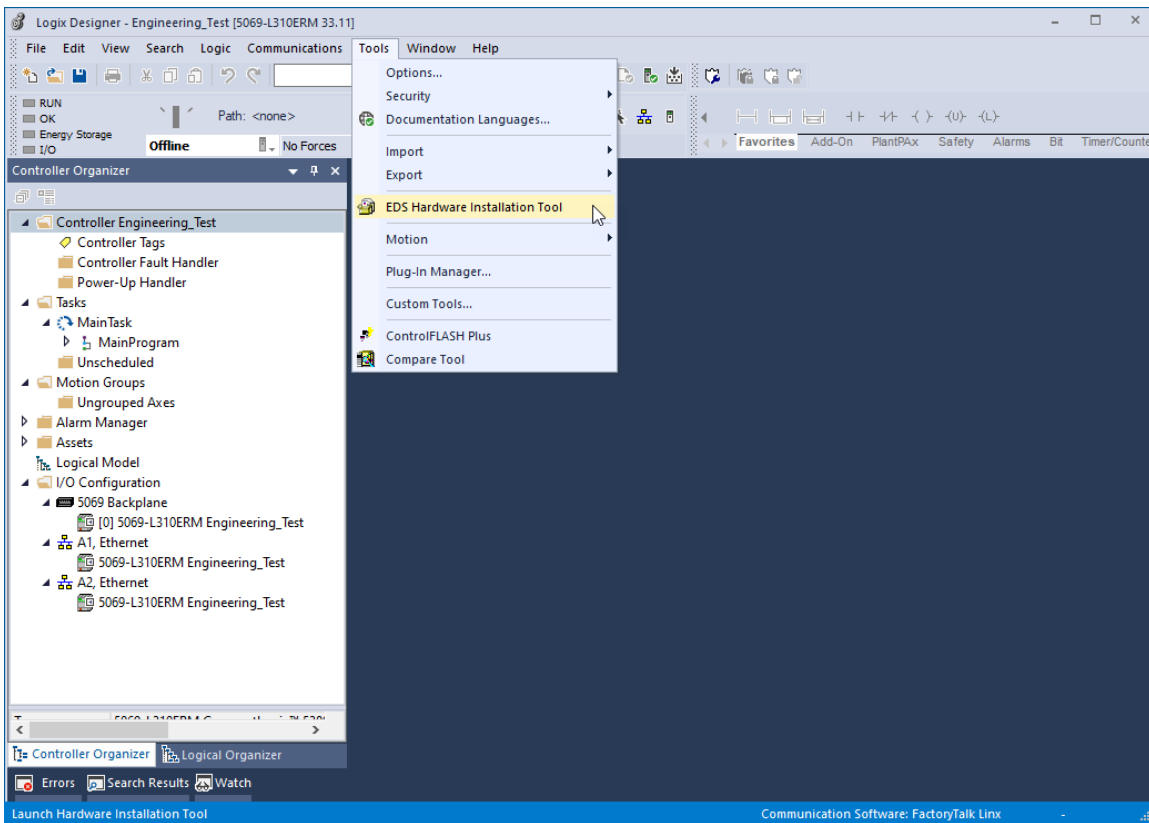

Figure 6.9: Tools -> EDS hardware installation tool

The “EDS installation hardware installation tool” will now open. Click on “next.”

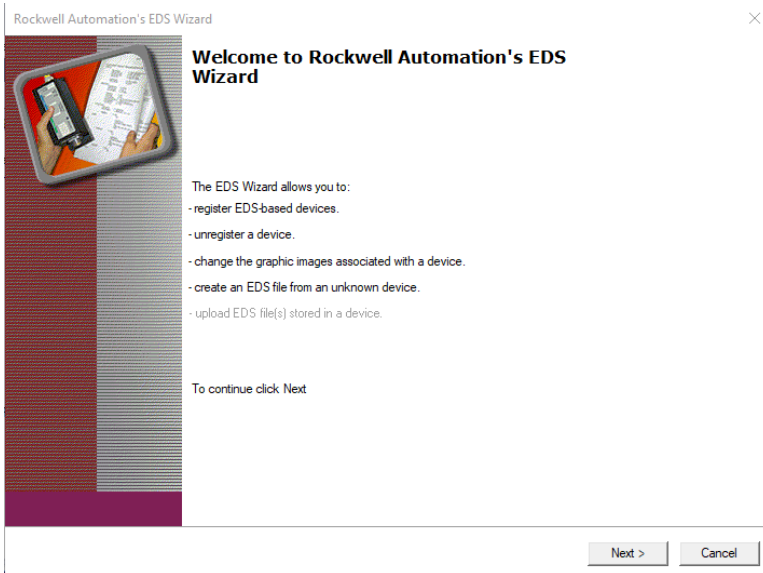

Figure 6.10: EDS hardware installation tool

Select "register an EDS file(s)" and click "next."

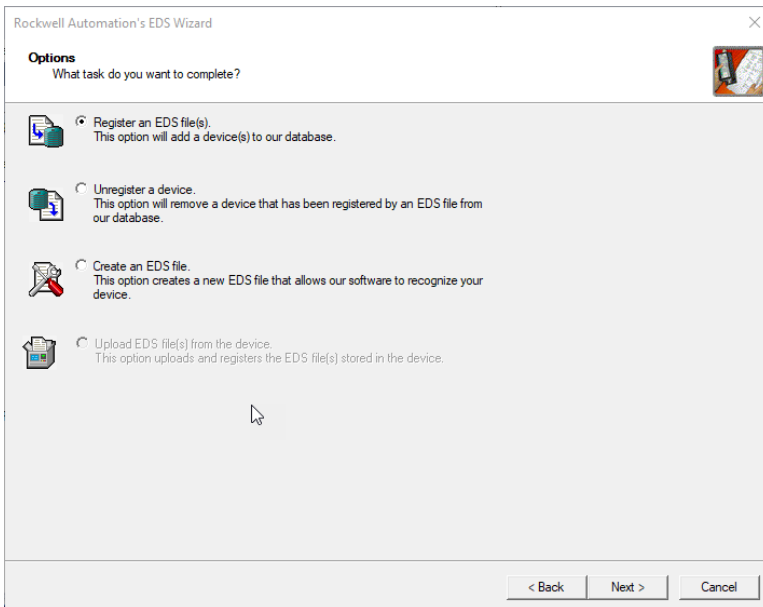

Figure 6.11: Register an EDS file

Next, select "register a single file" and paste the path of the EDS file. Then click on "next."

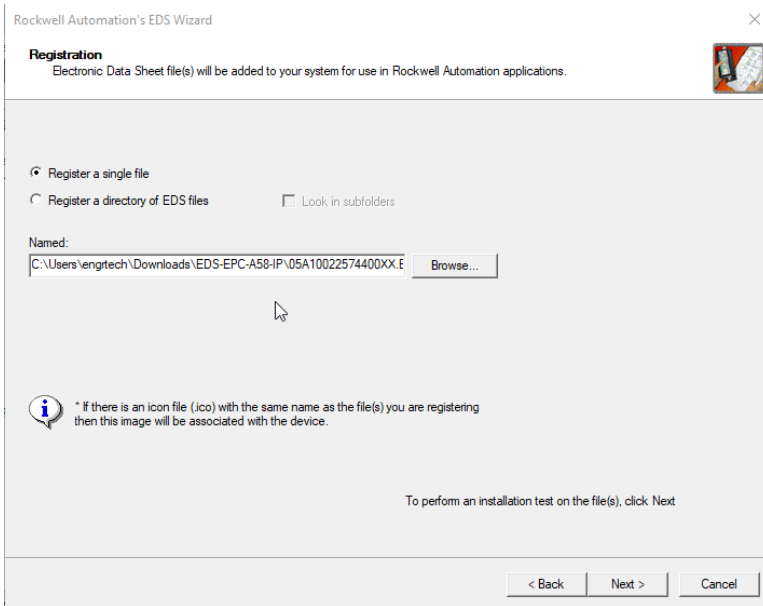

Figure 6.12: Select an EDS file

If you have selected the correct file, you should not have received an error message now. See Figure 6.13. Click "Next" again.

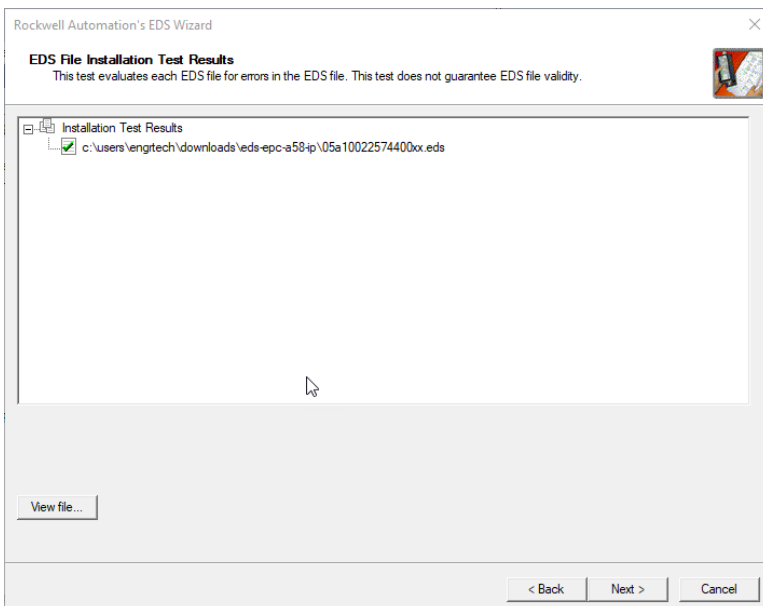

Figure 6.13: EDS installation

Now finish the installation by clicking on "next" in the following two windows until you reach the window shown in Figure 6.14.

Now click on “finish.” The installation of the EDS file is now finished.

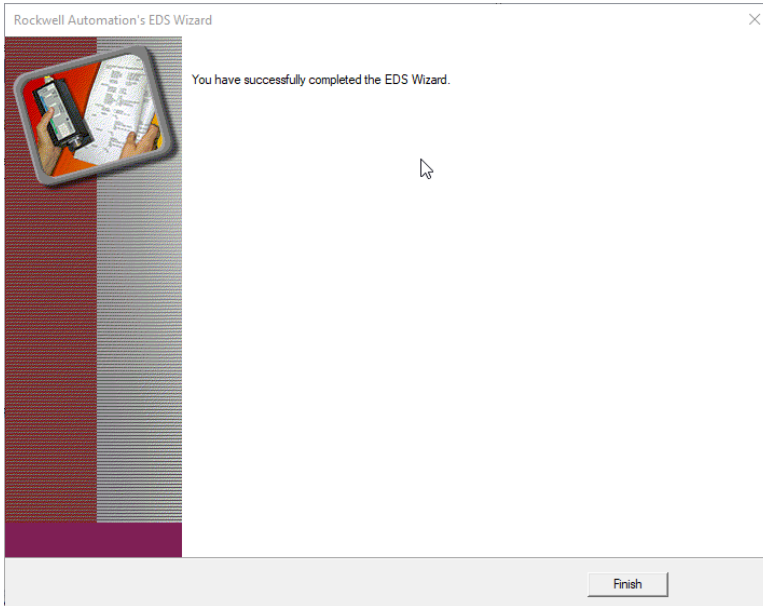

Figure 6.14: Installation successful

Now select the tab “A1/A2, Ethernet” in the left column of the Studio 5000 project navigation. The hardware view opens, and the hardware catalog is now visible in the new window. Select “new module.”

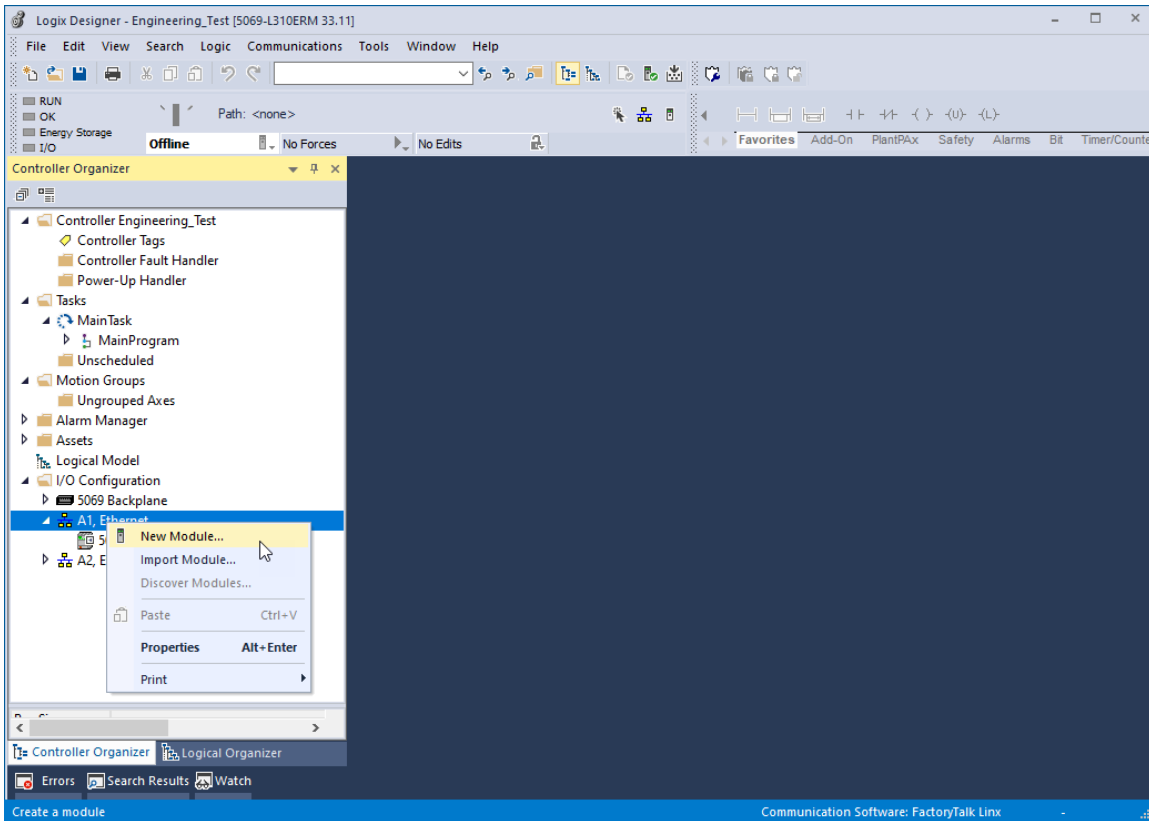

Figure 6.15: Project navigation

Search for “EPC” in the search bar and the EPC-A58-IP should now be displayed. Select the device and then click “create.”

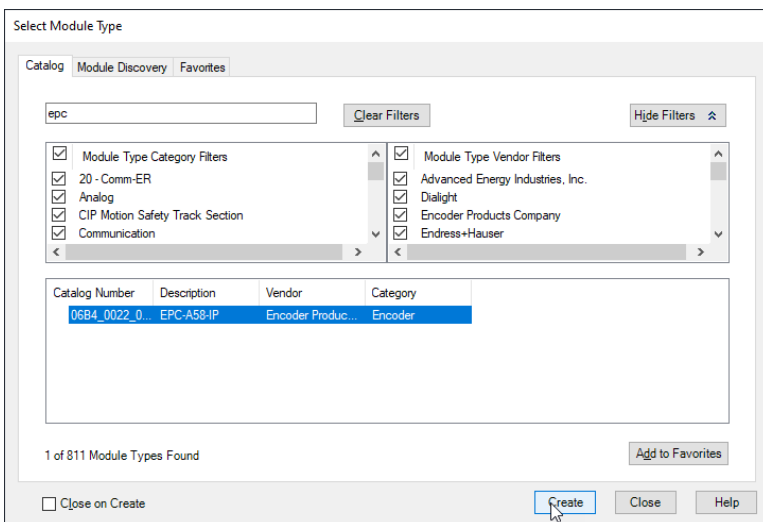

Figure 6.16: Hardware catalog

A window opens again in which you can select the name, the IP address, the description (optional), and the assemblies. You can find out which assembly is suitable for you from the tables in 4.3.

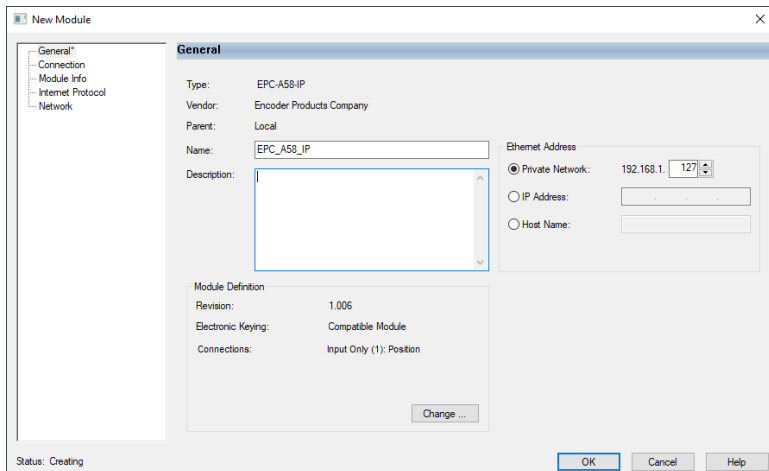

Figure 6.17: General

If you click on “change...” in the “general” window, you can set the assembly accordingly. In this chapter we will only work with Assembly 1 for the time being. We recommend selecting DINT for “size,” so that you receive the position value as a 32-bit block.

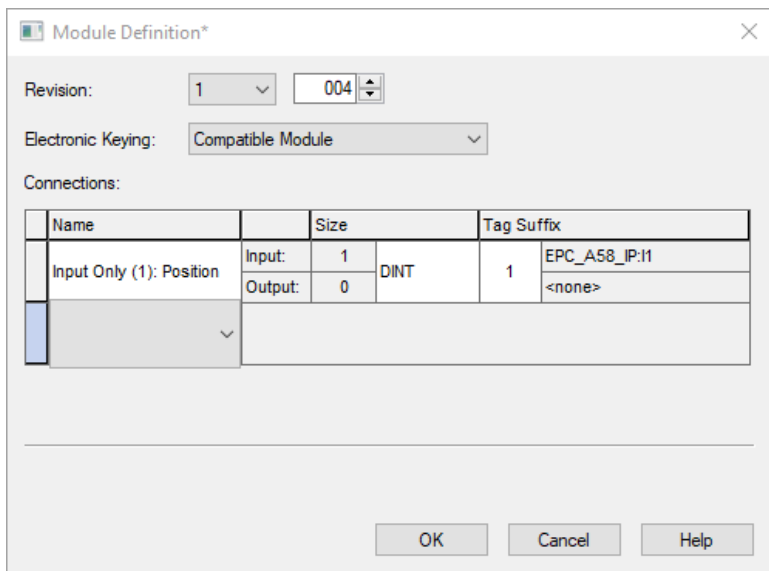

Figure 6.18: Choose assembly

Under the “connection” tab you can now set the cycle time (RPI) and the “connection over EtherNet/IP™.” Now click on “OK.” The encoder should now be displayed in the left column of the project navigation.

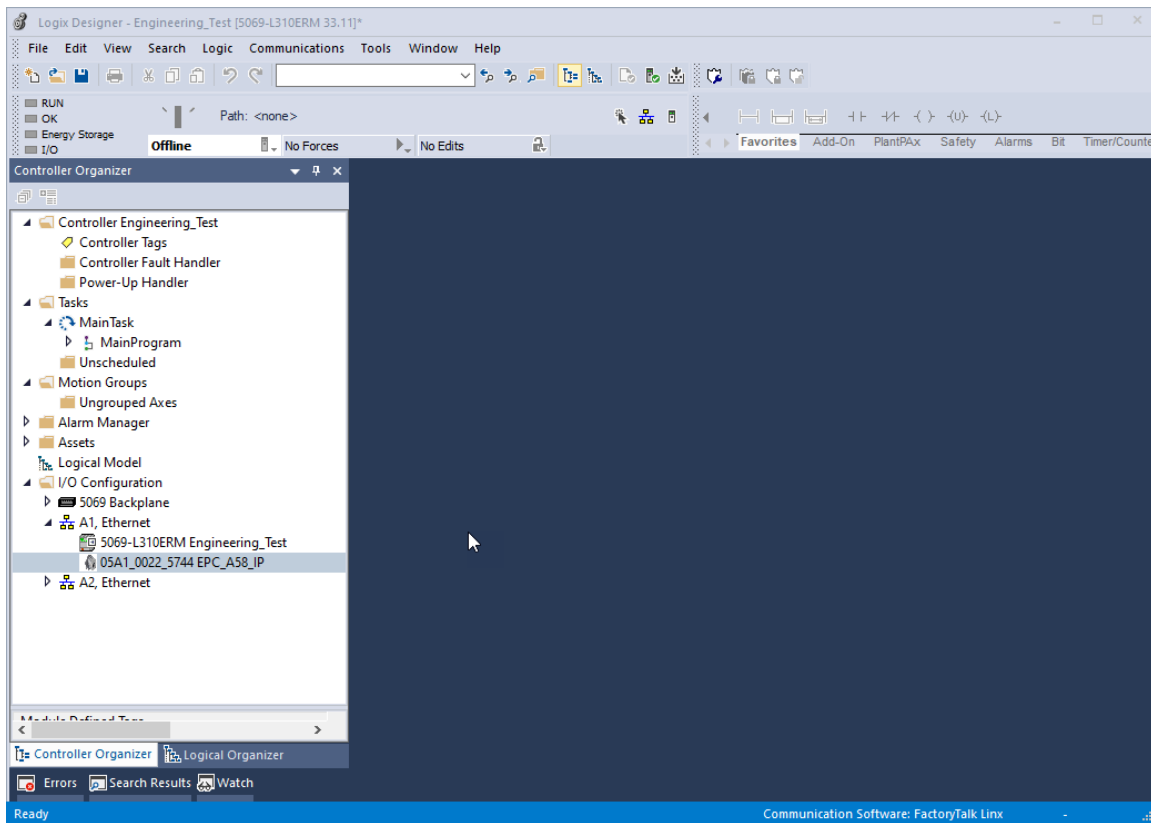

Figure 6.19: Encoder configuration successful

Now go online with the controller by downloading the program to the controller. Then navigate to the “controller tags” tab in the project navigation. First open the “EPC_A58_IP:11” tab and then the “EPC_A58_IP:11.Data” tab. Under “EPC_A58_IP:11.Data [0]” you will now see the position value.

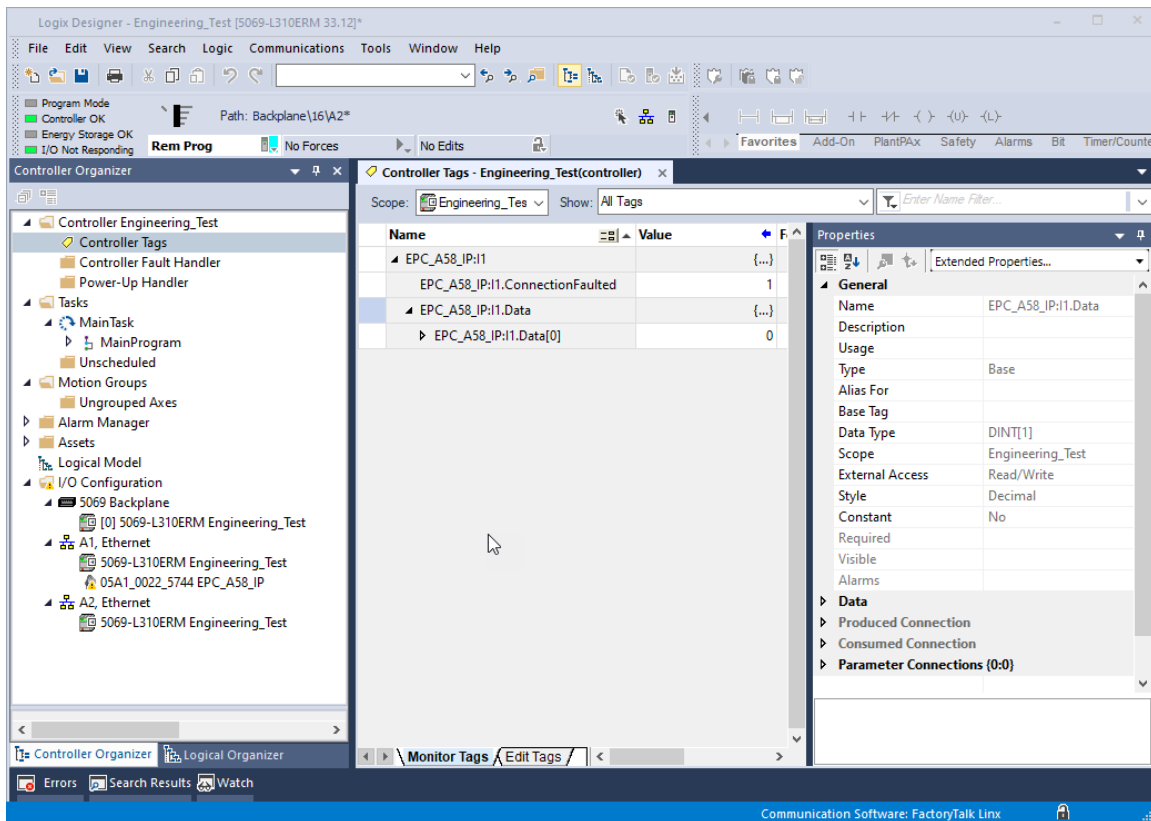

Figure 6.20: Position value

This concludes the integration of the encoder into the project for the time being. The following chapters will explain how you can configure the encoder according to your preferences. Two ways are shown to do this.

Parameterization via configuration assembly

A one-time parameterization of the encoder can be carried out by means of the configuration assembly. The parameters are only adopted when a new connection is established, i.e., the configuration assembly is not to be used during ongoing operation.



- After you have performed the one-time parameterization with the configuration assembly, it is recommended to remove it again.

First, open the “module properties” of the previously created device. Then select the “change...” button in the “general” window. Now select the connection “input only (101 + 110)” under “connections” and confirm with “OK.”

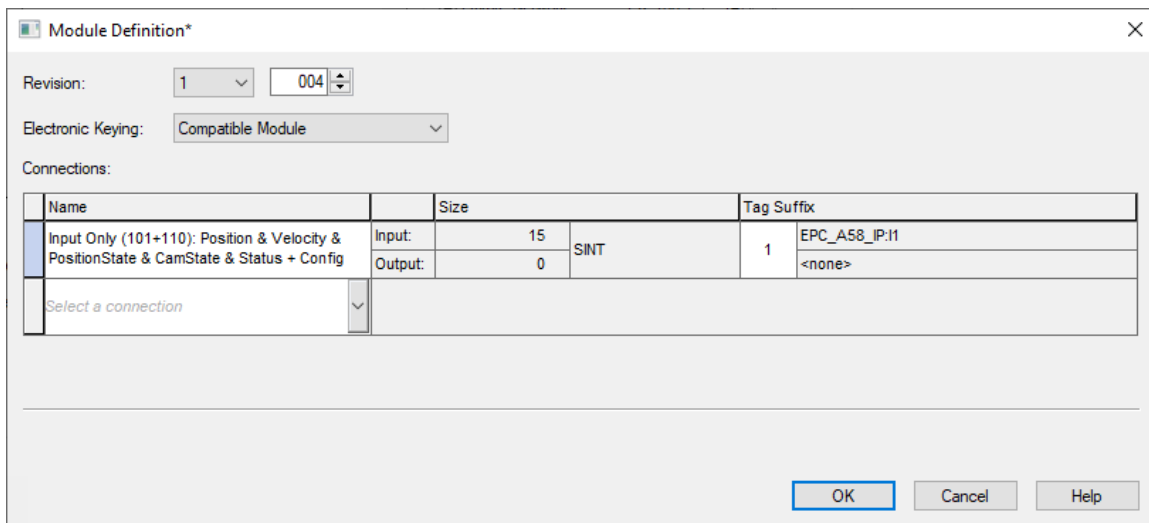

Figure 6.21: Module definition

This loads the assemblies 101 and 110 into the controller tags. Assembly 101 is used to view the process data, while Assembly 110 is used for configuration.

Now navigate to the controller tags. Under “EPC_A58_IP” you will find the parameters to be set.

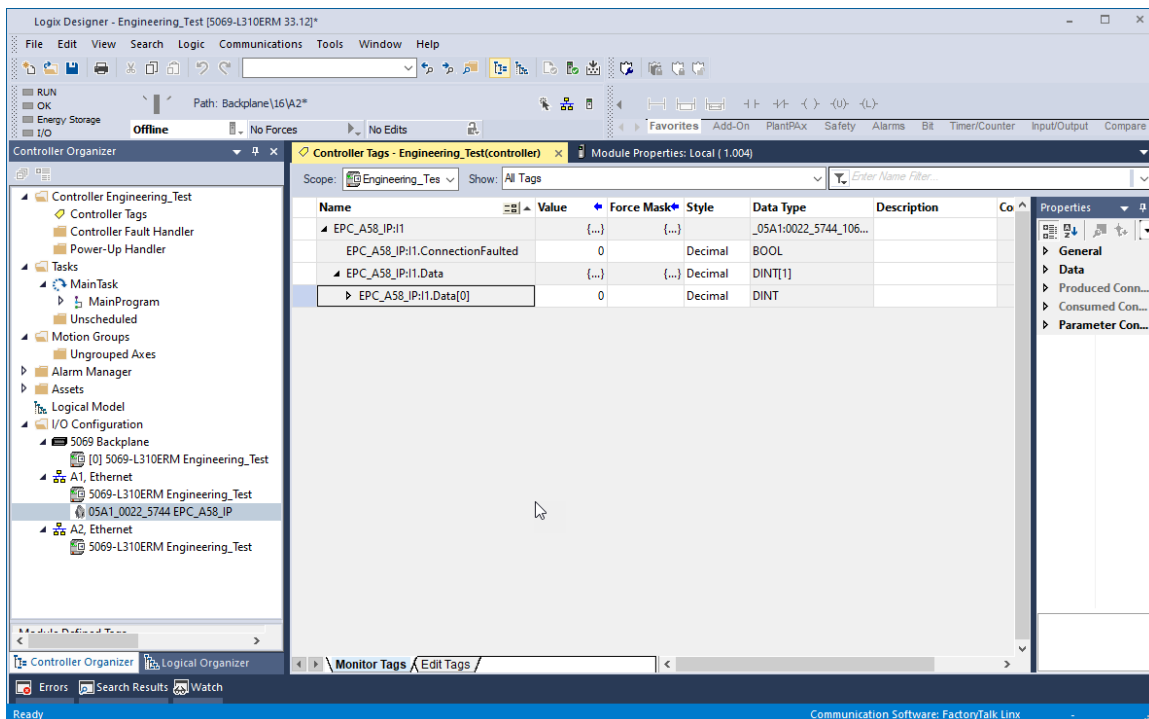

Figure 6.22: Controller tags

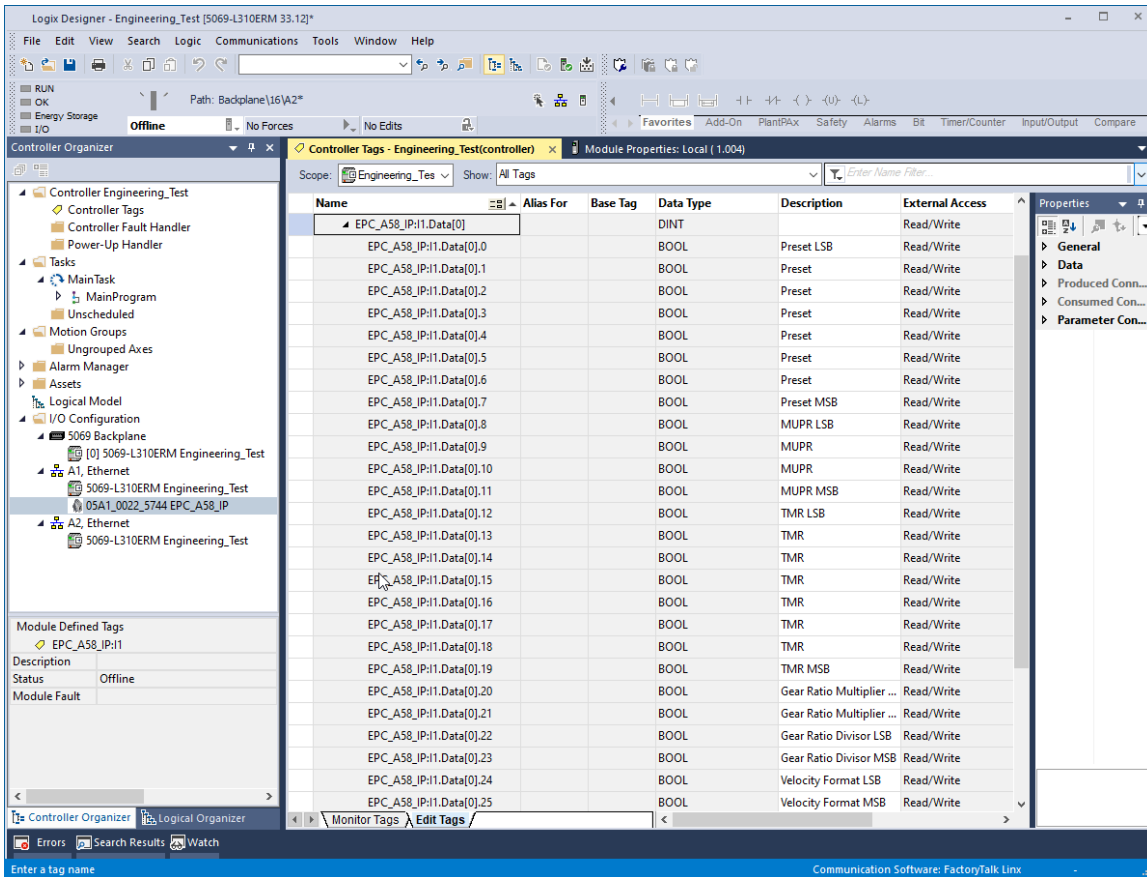

Figure 6.23: Configuration assembly

Setting the data format to “hex” is recommended. Here you can configure the parameters as desired. If you want to set e.g., the MUPR to 16-bit (65,535), the TMR to 32-bit (4,294,967,295), and the preset to 0. Then set the first 8 bytes to 0, bytes 8 and 9 to FFh, and bytes 12-15 also to FFh. In addition, you must set byte 26 to the value 06h, otherwise the preset will not be executed (bit 2 of byte 26 contains the preset execute).

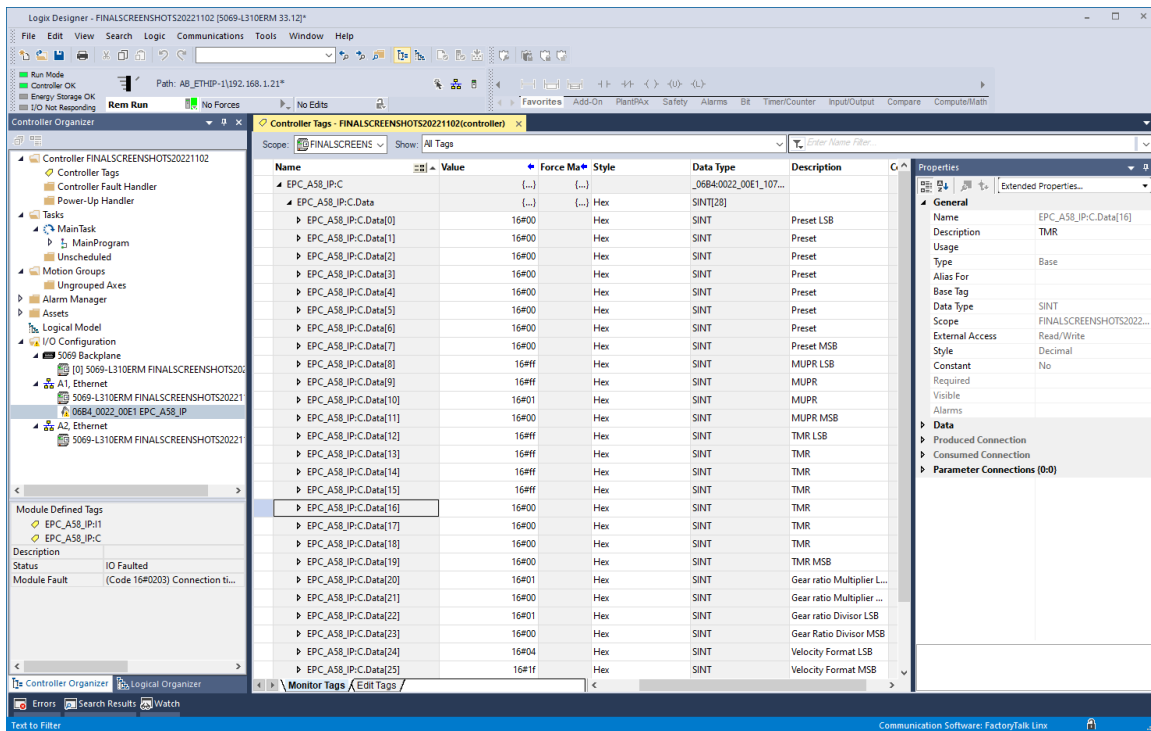

Figure 6.24: Example configuration

Now go online with the controller and download the program to the controller. Once the controller is online, you must establish a new connection with the device via a power cycle. Then check, for example in the web server, whether your parameters have been saved.



Language:



Information Configuration License Contact

Encoder

Current values

Raw position value:	-1294411
Scaled position value:	1294411
Offset value:	0
Speed value:	0

Setting

Code sequence:	Clockwise
Scaling enabled:	Yes
Measuring units per revolution:	65536
Total measuring range:	4294967295
Gear ratio:	1 / 1
Speed calculation source:	Scaled Position
Integration time:	1000 ms
Speed factor:	1 / 1

Figure 6.25: Encoder information

If all values have been accepted, the device is now fully commissioned and can be used.

Parameterization via explicit messaging

Explicit messaging treats each communication between devices as a separate request and response. Explicit messages can be sent by a client at any time and the server can respond as soon as it is available. Therefore, explicit messaging is used only for non-time-critical information, such as configuration data.

To parameterize the device using explicit messaging, first create a new PLC program (here: ladder logic).

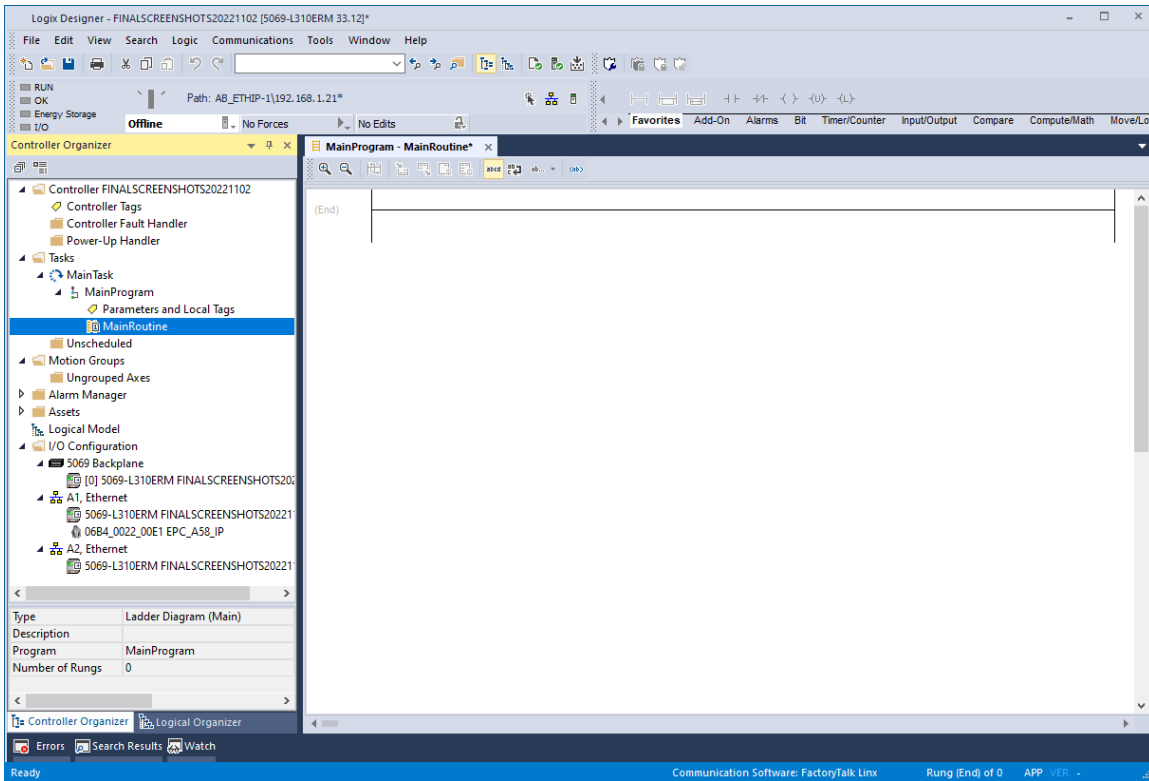

Figure 6.26: Example new program

Now add a device with the process data you require as described in chapter 6.4. Then navigate back to your previously created program. Select “parameters and local tags” there.

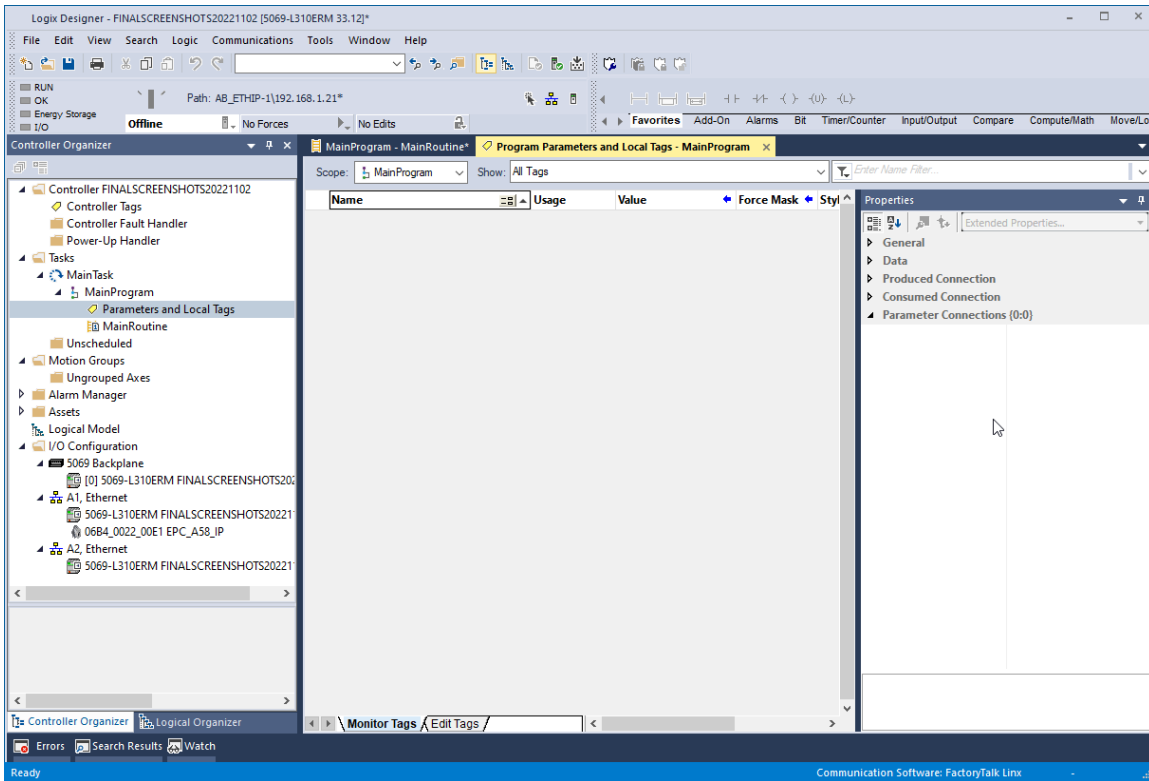

Figure 6.27: Parameters and tags

Now create the following tags to perform an example configuration:

- Send_MSG_TMR (message)
- Send_MSG_MUPR (message)
- Send_MSG_Preset (message)
- Send_MSG_Scaling (message)
- TMR_value (DINT)
- MUPR_value (DINT)
- Preset_value (DINT)
- Scaling_toggle (SINT)

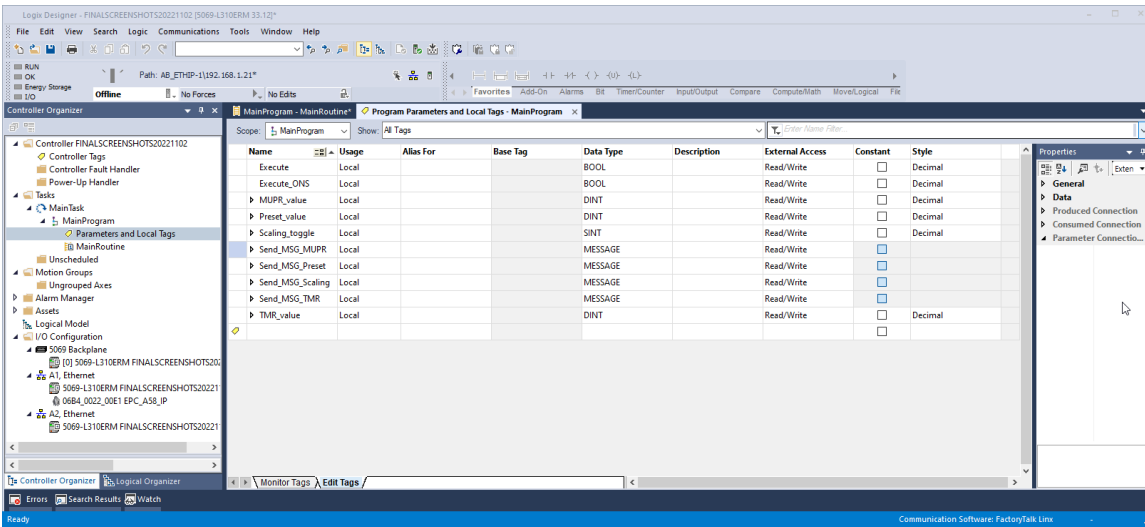

Figure 6.28: Parameters and tags

Now switch back to your main program. First select the main strand and add a closer (XIC) using the key combination Alt + Ins. Right-click the XIC symbol and select "New Tag." Configure as shown in Figure 6.29.

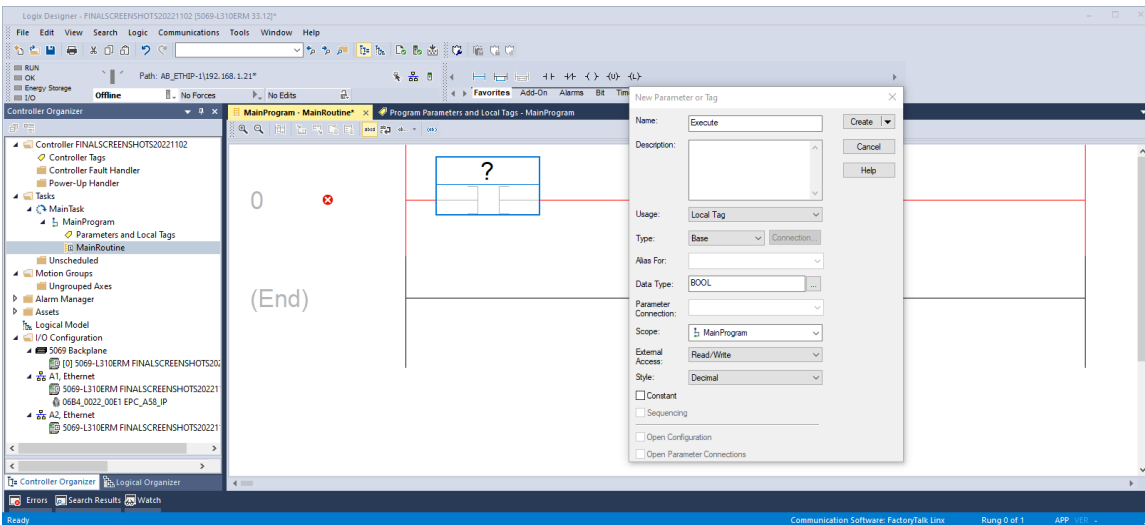

Figure 6.29: Rung edit

Then add a one shot (ONS) by pressing Alt + Ins again. Create label tag as shown in Figure 6.30.

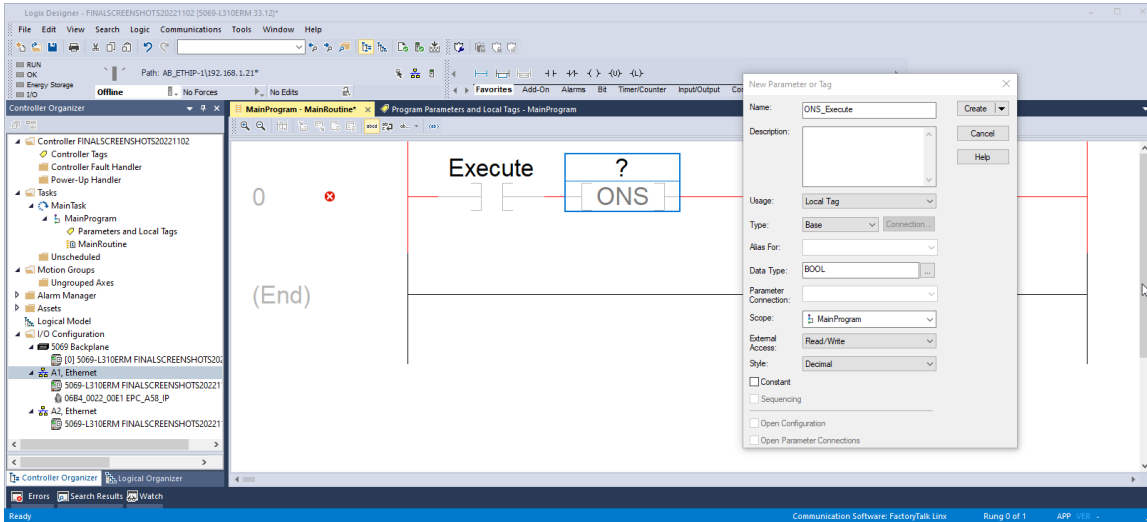

Figure 6.30: Rung edit

Next you add a MSG block. Then insert the name of the desired and previously created configuration into this block, e.g., TMR. Then click on the text box labeled “...” to enter the configuration of the MSG block.

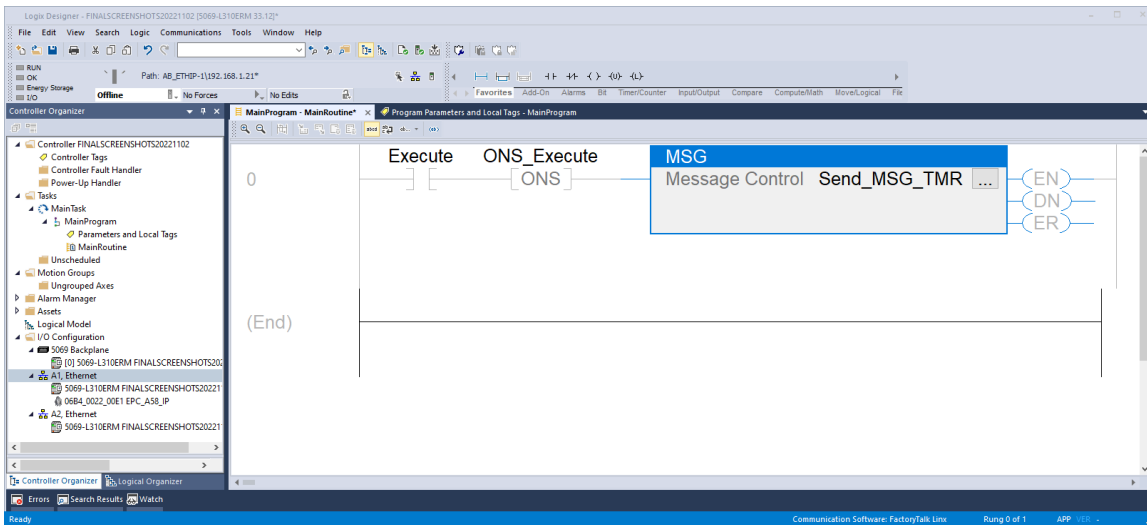

Figure 6.31: Rung edit

Configure the MSG block as shown in the figure below.

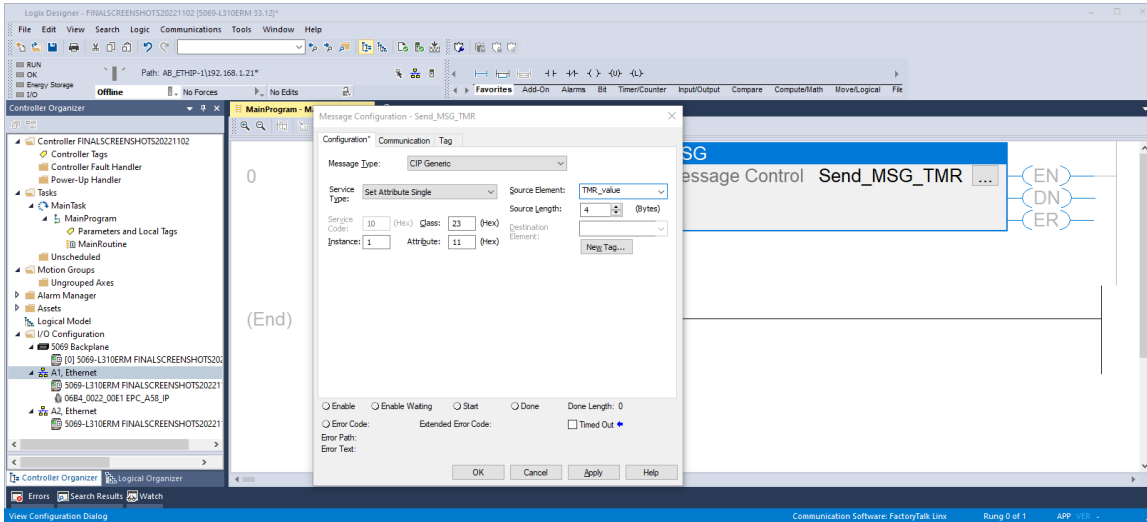

Figure 6.32: Rung edit

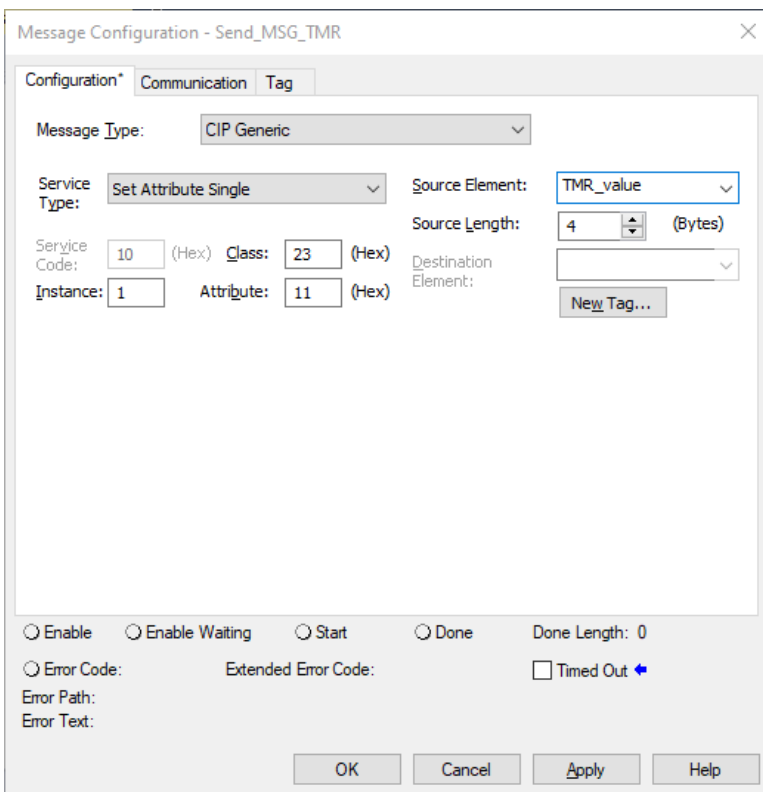

Figure 6.33: MSG block configuration

Under the “communication” tab, select the encoder as the path.

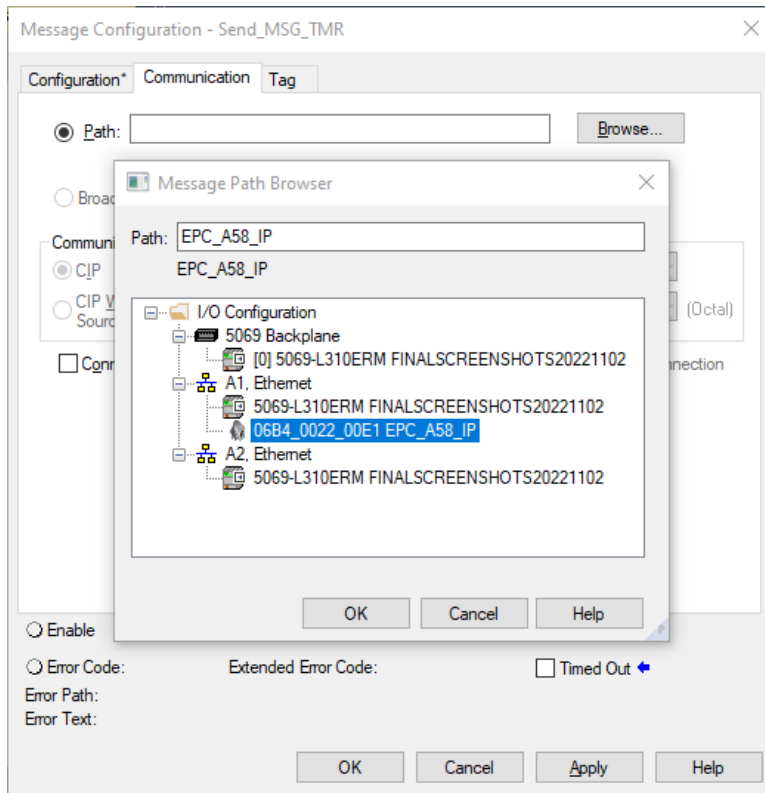

Figure 6.34: MSG block path configuration

Repeat this for all the tags you have created. Make sure that you assign the parameters correctly:

Attribute-ID	Hex	Message	Source element	Bytes
14 (Scaling)	E	Send_MSG_Scaling	Scaling_toggle	1
16 (MUPR)	10	Send_MSG_MUPR	MUPR_value	4
17 (TMR)	11	Send_MSG_TMR	TMR_value	4
19 (Preset)	13	Send_MSG_Preset	Preset_value	4

Table 6.1: Configurations

After you have created and configured everything, your program should look like the one below.

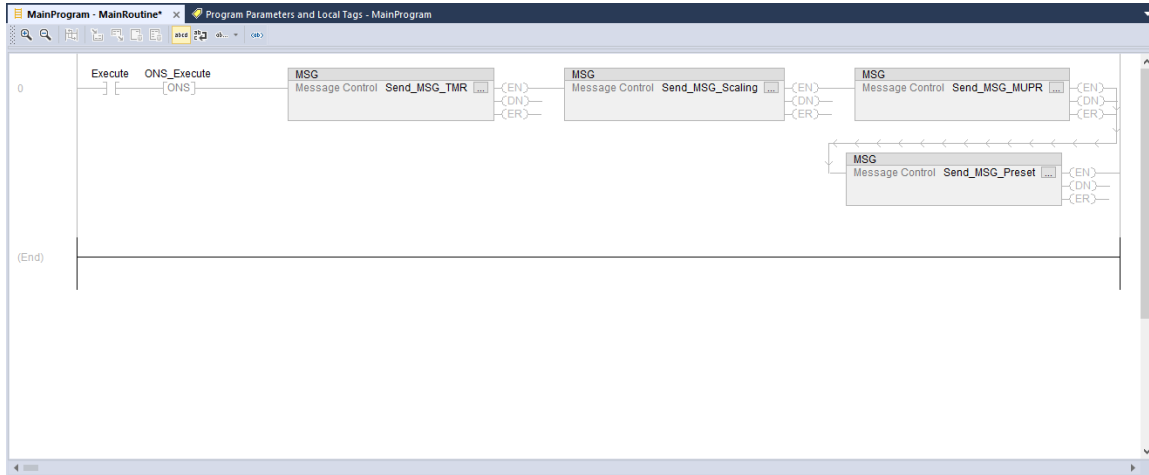

Figure 6.35: Configure the main program

Now go online with the controller and download the program you just edited. Then navigate back to the “program parameters and local tags” tab. Now enter the values you want.

For example, if you want to activate the scaling, define a shaft revolution with 0.1°, set the total measuring range to 10 revolutions and have the position value start at 0, then make the following settings.

Name	Usage	Value	Force Mask	Style	Data Type	Description	Constant
Execute	Local	16#0		Hex	BOOL		<input type="checkbox"/>
ONS_Execute	Local	16#0		Hex	BOOL		<input type="checkbox"/>
MUPR_value	Local	16#0000_0e10		Hex	DINT		<input type="checkbox"/>
Preset_value	Local	16#0000_0000		Hex	DINT		<input type="checkbox"/>
TMR_value	Local	16#0000_8ca0		Hex	DINT		<input type="checkbox"/>
Send_MSG_MUPR	Local	[...]		[...]	MESSAGE		<input type="checkbox"/>
Send_MSG_Preset	Local	[...]		[...]	MESSAGE		<input type="checkbox"/>
Send_MSG_Scaling	Local	[...]		[...]	MESSAGE		<input type="checkbox"/>
Send_MSG_TMR	Local	[...]		[...]	MESSAGE		<input type="checkbox"/>
Scaling_toggle	Local	16#01		Hex	SINT		<input type="checkbox"/>

Figure 6.36: Parameters and tags

Now switch back to your main program and activate the “execute” closer by selecting it and pressing Ctrl + T.

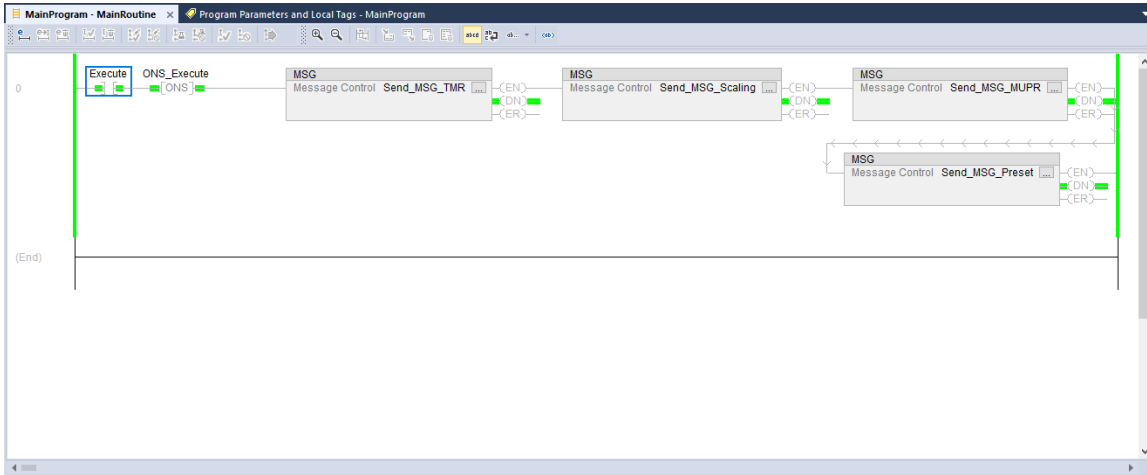

Figure 6.37: Configuration successful

If everything was successful, then each MSG block is in DN state. Check your settings by looking at the web server, for example.

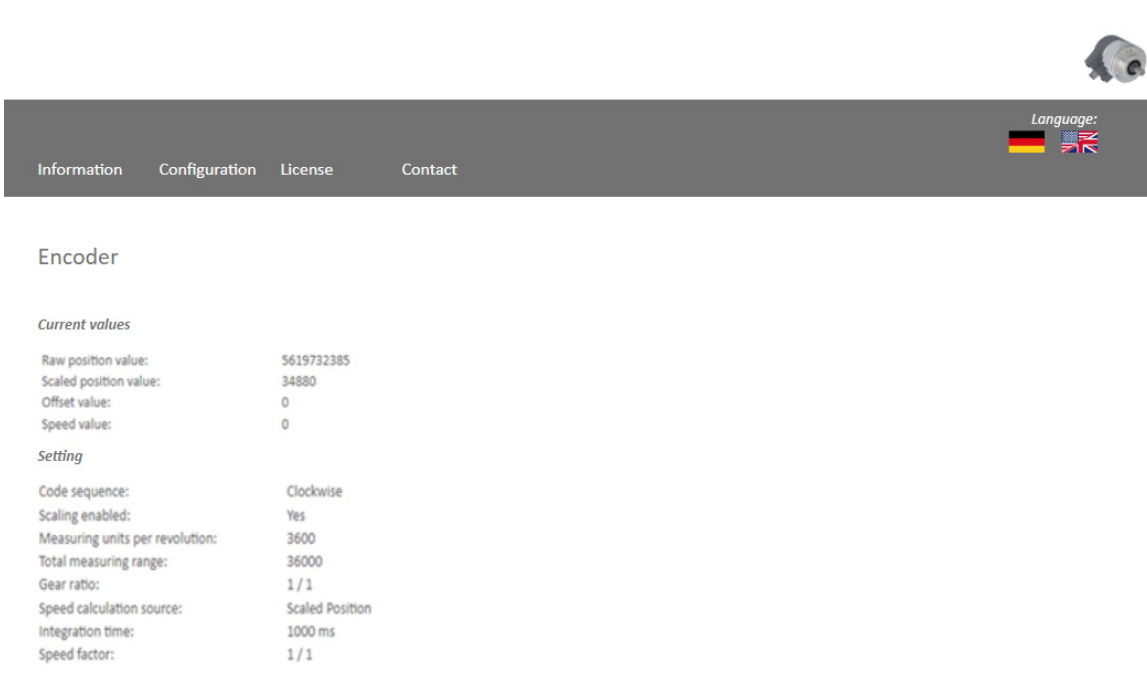

Figure 6.38: Webservice after successful completion

6.5 Further configuration options

Position limits

If you need software limit switches, it is recommended to use position low/high limits. To use these, proceed as described in Chapter 6.4, under Parameterization via Explicit Messaging. Select the desired values for the limits, e.g., low limit = 500, high limit = 1500. Configure the messages as shown below.

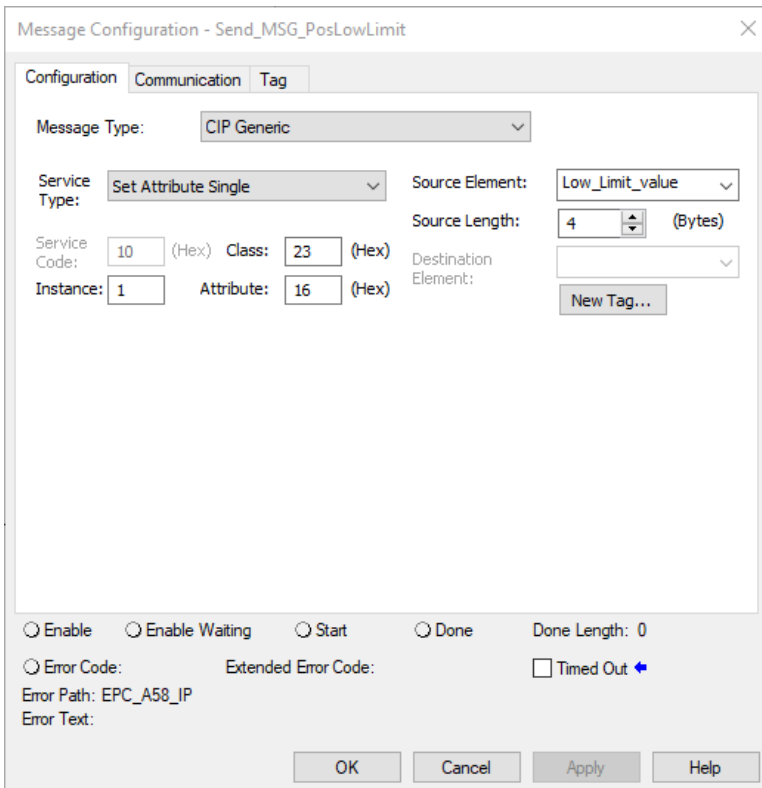

Figure 6.39: MSG position low limit

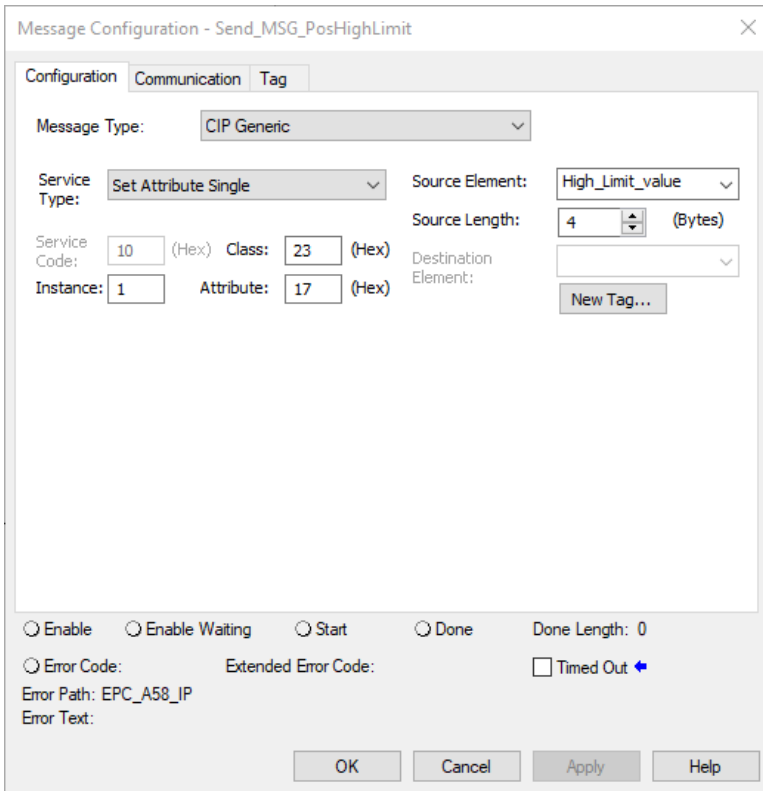

Figure 6.40: MSG position high limit

Then navigate to the encoder configuration and select “assembly 100.”

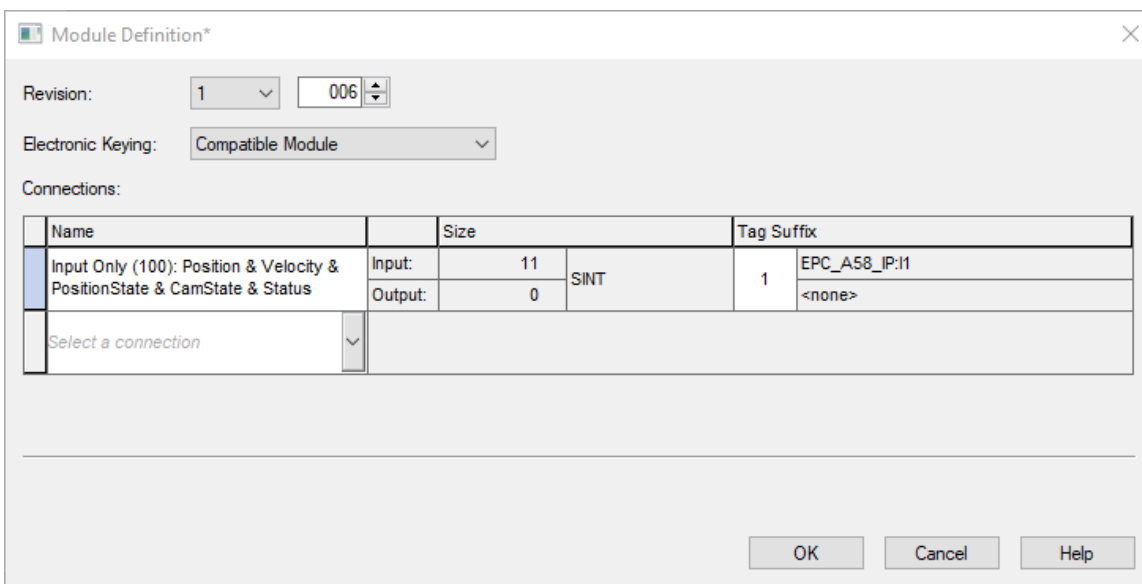

Figure 6.41: Assembly 100

Now switch back to the “controller tags.” Under “EPC_A58_IP:11.Data[8]” you can now see whether you are inside or outside the work area.

Name	Value	For	Style	Data Type	Description	Constant
▲ EPC_A58_IP:11	{...}	{...}		_06B4:0022_00E1_62DB3186:I:0		<input type="checkbox"/>
EPC_A58_IP:11.ConnectionFaulted	0		Decimal	BOOL		
▲ EPC_A58_IP:11.Data	{...}	{...}	Hex	SINT[15]		
▶ EPC_A58_IP:11.Data[0]	16#76		Hex	SINT		
▶ EPC_A58_IP:11.Data[1]	16#03		Hex	SINT		
▶ EPC_A58_IP:11.Data[2]	16#00		Hex	SINT		
▶ EPC_A58_IP:11.Data[3]	16#00		Hex	SINT		
▶ EPC_A58_IP:11.Data[4]	16#00		Hex	SINT		
▶ EPC_A58_IP:11.Data[5]	16#00		Hex	SINT		
▶ EPC_A58_IP:11.Data[6]	16#00		Hex	SINT		
▶ EPC_A58_IP:11.Data[7]	16#00		Hex	SINT		
▶ EPC_A58_IP:11.Data[8]	16#00		Hex	SINT		
▶ EPC_A58_IP:11.Data[9]	16#00		Hex	SINT		
▶ EPC_A58_IP:11.Data[10]	16#00		Hex	SINT		

Figure 6.42: Position state register inside work area

Name	Value	For	Style	Data Type	Description	Constant
▲ EPC_A58_IP:11	{...}	{...}		_06B4:0022_00E1_62DB3186:I:0		<input type="checkbox"/>
EPC_A58_IP:11.ConnectionFaulted	0		Decimal	BOOL		
▲ EPC_A58_IP:11.Data	{...}	{...}	Hex	SINT[15]		
▶ EPC_A58_IP:11.Data[0]	16#41		Hex	SINT		
▶ EPC_A58_IP:11.Data[1]	16#88		Hex	SINT		
▶ EPC_A58_IP:11.Data[2]	16#00		Hex	SINT		
▶ EPC_A58_IP:11.Data[3]	16#00		Hex	SINT		
▶ EPC_A58_IP:11.Data[4]	16#00		Hex	SINT		
▶ EPC_A58_IP:11.Data[5]	16#00		Hex	SINT		
▶ EPC_A58_IP:11.Data[6]	16#00		Hex	SINT		
▶ EPC_A58_IP:11.Data[7]	16#00		Hex	SINT		
▶ EPC_A58_IP:11.Data[8]	16#00		Hex	SINT		
▶ EPC_A58_IP:11.Data[9]	16#00		Hex	SINT		
▶ EPC_A58_IP:11.Data[10]	16#02		Hex	SINT		

Figure 6.43: Position state register outside work area

Preset attribute 140h

If you have already executed a preset as explained in Chapter 6.4.2, you can use “preset execute” to set the position value to the previously defined preset value again. Proceed as explained in the previous chapters.

7. Technical data

7.1 Properties

Interfaces	1x M12 port 4-pin D-coded	
	2x M12 connector 4-pin A-coded	
EtherNet/IP™ data rate	Max. 100 Base-TX	
Diagnostic LEDs	Data traffic and connection monitoring:	L/A1: Port 1, L/A2: Port 2
Status LEDs	Status display for encoder and bus:	MOD
Operating temperature	-40° C to 85° C	
Storage temperate	-40° C to 125° C	
Operating voltage	10 VDC to 32 VDC	
Current consumption	Typ. 125 mA	
Power consumption	Typ. 3 W	
Weight	A58SE	Approx. 700 g
	A58HE	Approx. 410 g
Housing	Flange material:	Aluminum
	Flange material (rear):	Steel housing, chromium-plated, magnetically shielded
	Connection hood:	Die-cast aluminum, powder-coated

7.2 Dimensions

7.2.1 Model A58SE Clamping Flange (MH)

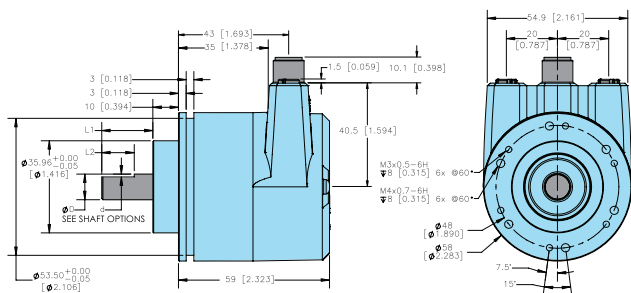

SHAFT SIZE	ØD	L1	d	L2
6mm	6 [0.236]	12 [0.472]	0.7 [0.028]	10 [0.394]
8mm	8 [0.315]	19 [0.748]	0.5 [0.020]	15 [0.591]
10mm	10 [0.394]	20 [0.787]	no flat	n/a
3/8"	9.5 [0.375]	20 [0.787]	1.2 [0.047]	10 [0.394]

Figure 7.1: Dimensions Model A58SE Clamping Flange (MH)

7.2.2 Model A58SE Synchro Flange (MK)

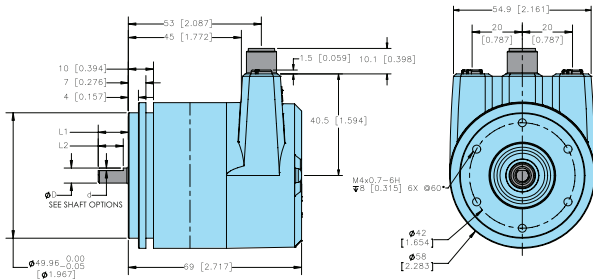

SHAFT SIZE	ØD	L1	d	L2
6mm	6 [0.236]	12 [0.472]	0.7 [0.028]	10 [0.394]
8mm	8 [0.315]	19 [0.748]	0.5 [0.020]	15 [0.591]
10mm	10 [0.394]	20 [0.787]	no flat	n/a
3/8"	9.5 [0.375]	20 [0.787]	1.2 [0.047]	10 [0.394]

Figure 7.2: Model A58SE Synchro Flange (MK)

7.2.3 Model A58SE Clamping Flange Heavy Duty (MM)

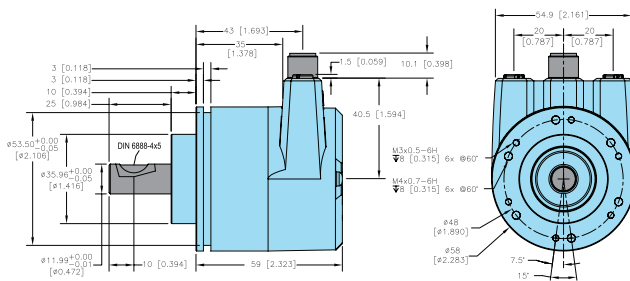
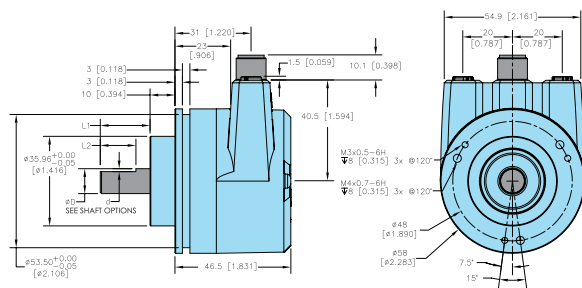

Figure 7.3: Model A58SE Clamping Flange Heavy Duty (MM)

7.2.4 Model A58SE Clamping Flange Compact (MP)



SHAFT SIZE	ØD	L1	d	L2
6mm	6 [0.236]	12 [0.472]	0.7 [0.028]	10 [0.394]
8mm	8 [0.315]	19 [0.748]	0.5 [0.020]	15 [0.591]
10mm	10 [0.394]	20 [0.787]	no flat	n/a
3/8"	9.5 [0.375]	20 [0.787]	1.2 [0.047]	10 [0.394]

Figure 7.4: Model A58SE Clamping Flange Compact (MP)

7.2.5 Model A58HE 63 mm 2-point flex mount (SR)

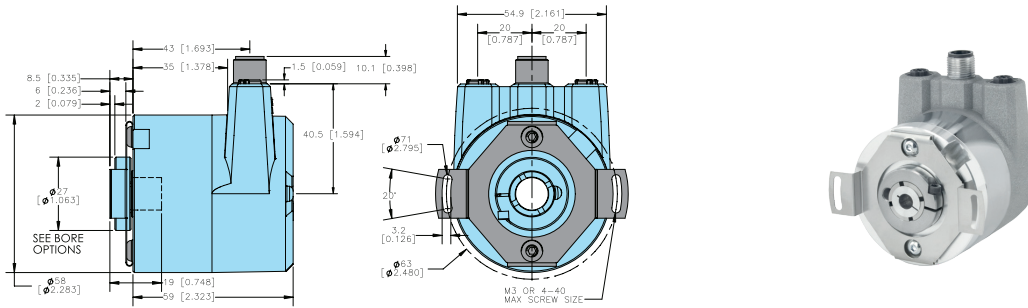

Figure 7.5: Model A58HE 63 mm 2-point flex mount (SR)

Primary dimensions are in millimeters, secondary dimensions in SI units [inches] in brackets are for reference only.

EPC RESERVES THE RIGHT TO UPDATE, REVISE, AND AMEND ALL SOFTWARE AND TECHNICAL DATA OR CONTENT AT ANY TIME. EPC SHALL HAVE NO LIABILITY OF ANY KIND OR NATURE FOR ANY TECHNICAL ERRORS OR OMISSIONS IN ANY SOFTWARE OR TECHNICAL DATA. SEE ENCODER.COM FOR MORE INFORMATION.

8. Technical support

If you need technical support, please contact:

British Encoder Products Company

Phone: +44(0)1978 262100

Fax: +44(0)1978 262101

Email: sales@encoder.co.uk