

## TB-534: Model 30M Installation with a Motor Adapter

There are numerous ways to successfully install an BEPC Model 30M in your application. BEPC's Applications Department is available to help identify and design the most cost-effective and easiest installation method for your application. The majority of applications can have the centering and gapping features designed into an adapter between the device it is being mounted to and the Model 30M (this is the preferred solution).

Magnet holders pictured were designed by BEPC to align the magnet with the encoder's sensor to provide optimum performance. Regardless of the magnet or magnet holder used, once installation is complete, the **magnet and encoder should be centered to the motor's shaft**, and **the magnet properly distanced from the encoder's sensor** to ensure proper feedback.

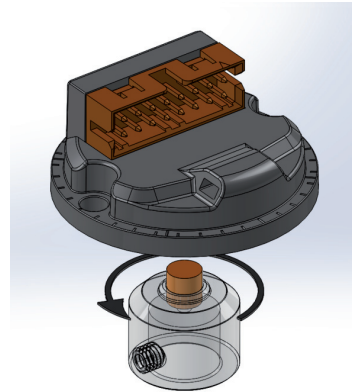

### Installation with motor adapter with built-in centering/gapping features:

- Centering: Boss/Pilot centers adapter to motor and encoder to adapter.
- Gapping: Raised lip (2.2mm tall) provides reference for top surface of magnet.

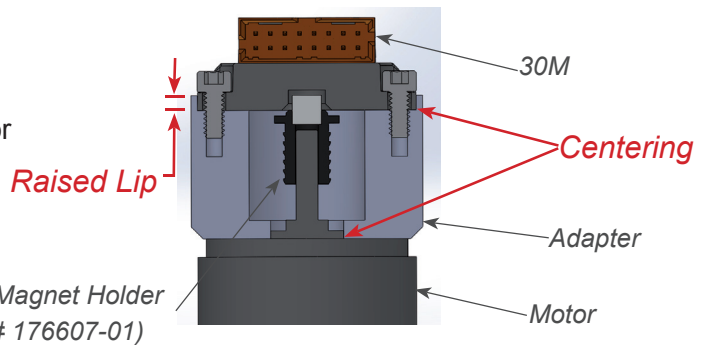

**NOTE:** Adapter shown in pictures below is an example.

#### Step 1



Secure adapter to motor.

#### Step 2



Install Magnet Holder, with magnet in place, over motor's shaft.

**NOTE:** If magnet holder has set screws, tighten screws before proceeding.



#### Step 3



Use a straight edge to ensure magnet is positioned flush with surface.

#### Step 4



Install 30M Encoder Module on adapter with mounting screws.