

TB-541: Ethernet Absolute Encoder Hardware Installation Guide

These are installation instructions for Models A58SE and A58HE. NOTE: These encoders are only designed and produced for use in industrial environments and NOT for use in safety related applications.

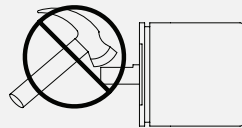

Do not shock or strike.

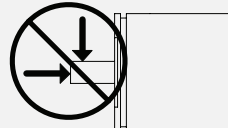

Do not subject shaft to excessive axial or radial shaft stresses.

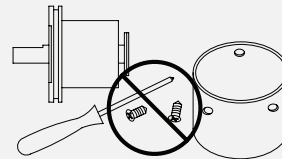

Do not disassemble.

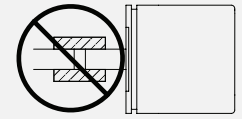

Do not use a rigid coupling.

Hollow Bore Mounting

The maximum recommended motor axial endplay is $\pm 0.030''$. Maximum motor TIR is $0.007''$.

Step 1

Slide the Model A58HE encoder over the motor shaft. If needed, clean the motor shaft of any burrs using a fine crocus cloth.

DO NOT USE UNDUE FORCE.

Position the encoder so that the flex mount arms just touch the mounting surface. Install screw(s) through the holes in the flex mount and tighten onto the motor securely. For additional security, add a drop of Loctite or similar thread locker to the threads of the screws.

Step 2

Using a 2.5 mm hex wrench, tighten the setscrew in the encoder's clamping collar. (Typical torque range of 50 to 80 oz-in). For additional security, add a drop of Loctite or similar thread locker to the threads of the set screw. Do not allow thread locker to run into the bore or onto the encoder bearings.

Step 3 (2 pt. flex mount option only)

For encoders with the 2 pt. flex mount option, the home position can be adjusted by loosening the mounting screws and rotating the encoder to the desired position, then re-tightening the screws.

ALIGNMENT NOTE: When turning the motor shaft by hand, the rocking movement of the encoder should be minimal. If not, loosen the encoder clamping collar set screw and rotate the encoder bore relative to the motor shaft to reposition the encoder until this movement is minimized.

When tightening the screw(s) or set screws, avoid holding the motor shaft with anything that may scar or burr the shaft.

Removal

Loosen (do not remove) the screw in the clamping collar. Then remove the flex mount screws and gently slide the encoder off the motor shaft.

Bore Size	F_r max.	F_a max.
\varnothing 6 mm	80 N (17.9 lb)	50 N (11.2 lb)
\varnothing 8 mm		
\varnothing 10 mm		
\varnothing 15 mm		
\varnothing 0.250"		
\varnothing 0.375"		

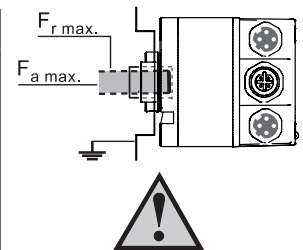

Diameter (D)	L_{min}	L_{max}
6, 7, 8, 10, 12, 14, or 15 mm and 0.250" and 0.375"	10 mm	19 mm

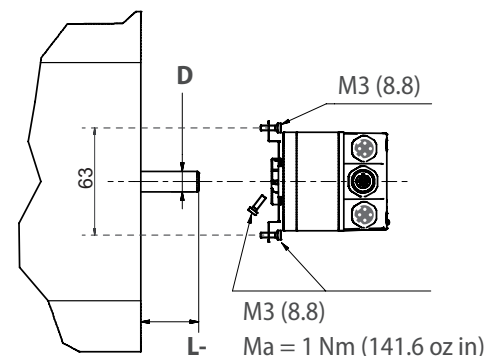

TB-541: Ethernet Absolute Encoder Hardware Installation Guide

Shaft Mounting

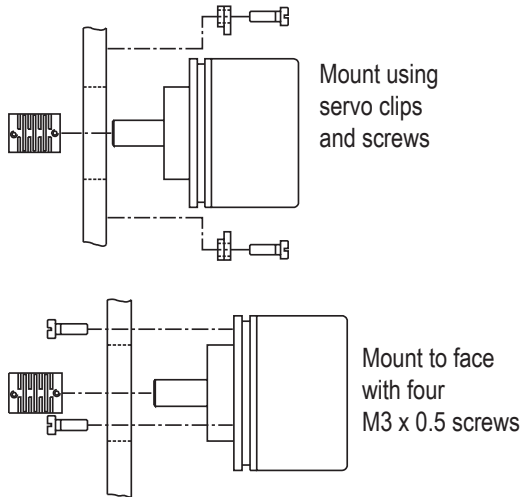

Shaft Size	F _r max.	F _a max.
MH & MK Mounts		
Ø 6 mm	125 N (28.1 lb)	120 N (26.9 lb)
Ø 8 mm	125 N (28.1 lb)	120 N (26.9 lb)
Ø 10 mm	220 N (49.4 lb)	120 N (26.9 lb)
Ø 0.375"	220 N (49.4 lb)	120 N (26.9 lb)
MP Mount		
Ø 6 mm	60 N (13.4 lb)	50 N (11.2 lb)
Ø 8 mm	60 N (13.4 lb)	50 N (11.2 lb)
Ø 10 mm	60 N (13.4 lb)	50 N (11.2 lb)
Ø 0.375"	60 N (13.4 lb)	50 N (11.2 lb)
MM Mount		
Ø 12 mm	400 N (89.9 lb)	400 N (89.9 lb)

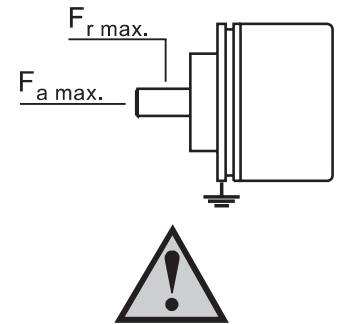

Face Mounting

A58SE with Clamping Flange:
Mounts with 6 x M3 screws
Ma = 1 Nm (141.6 oz in)

A58SE with Clamping or Synchro Flange:
Mounts with 6 x M4 screws
Ma = 2 Nm (283.2 oz in)

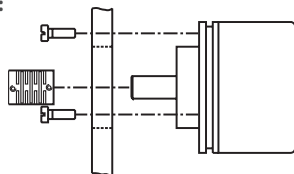

Clamping Flange Mounting

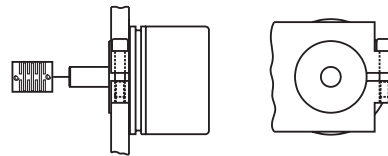

Servo Clip Mounting

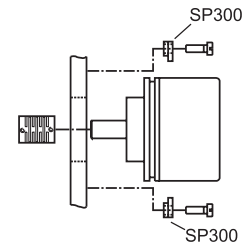

Female Connector Port1 (IN)



Function	M12x1, 4-pin, D-coded
Tx+	1
Rx+	2
Tx-	3
Rx-	4

Power



Function	M12x1, 4-pin, A-coded
(+) Vcc	1
n. c.	2
GND	3
n. c.	4

Female Connector Port2 (OUT)



Function	M12x1, 4-pin, D-coded
Tx+	1
Rx+	2
Tx-	3
Rx-	4

EtherCAT® (Ethernet for Control and Automation Technology) is a registered trademark and patented technology, licensed by Beckhoff Automation GmbH, Germany.
EtherNet/IP™ is a trademark of ODVA, Inc.
PROFINET® is a registered trademark and patented technology, licensed by PU (PROFIBUS & PROFINET) International.