

Model 58TF Incremental Thru-bore Encoder



Ø58.0 mm

FEATURES

- 58 mm Thru-Bore or Hollow Bore Encoder
- Standard and Metric Thru-Bore Sizes up to 5/8" and 15 mm
- Resolution from 1 to 65,536 PPR
- Several Flexible Mounting Options
- Sealing Options up to IP67
- Multiple Connector Options

The Model 58TF is a 58 mm thru-bore encoder that is specifically designed for the challenges of an industrial environment. Its advanced set of electronics allow the encoder to be configured to meet your exact application needs. Choose from 6 output types, 32 different waveforms, and select any resolution from 1 to 65,536 PPR (that's 262,144 counts in full quadrature). The Model 58TF is also highly mechanically configurable, with bore options up to 5/8" or 15 mm, several flexible mounting options, multiple connector options, and sealing up to IP67. This versatile thru-bore encoder can go in almost any application.

Common Applications

Motor Control, Conveyors, Elevator Controls, Machine Control, Food Processing, Process Control, Robotics, Material Handling, Textile Machines and all types of Motion Control Feedback

Model 58TF Ordering Guide

Blue type indicates price adder options. Not all configuration combinations may be available. Contact Customer Service for details.

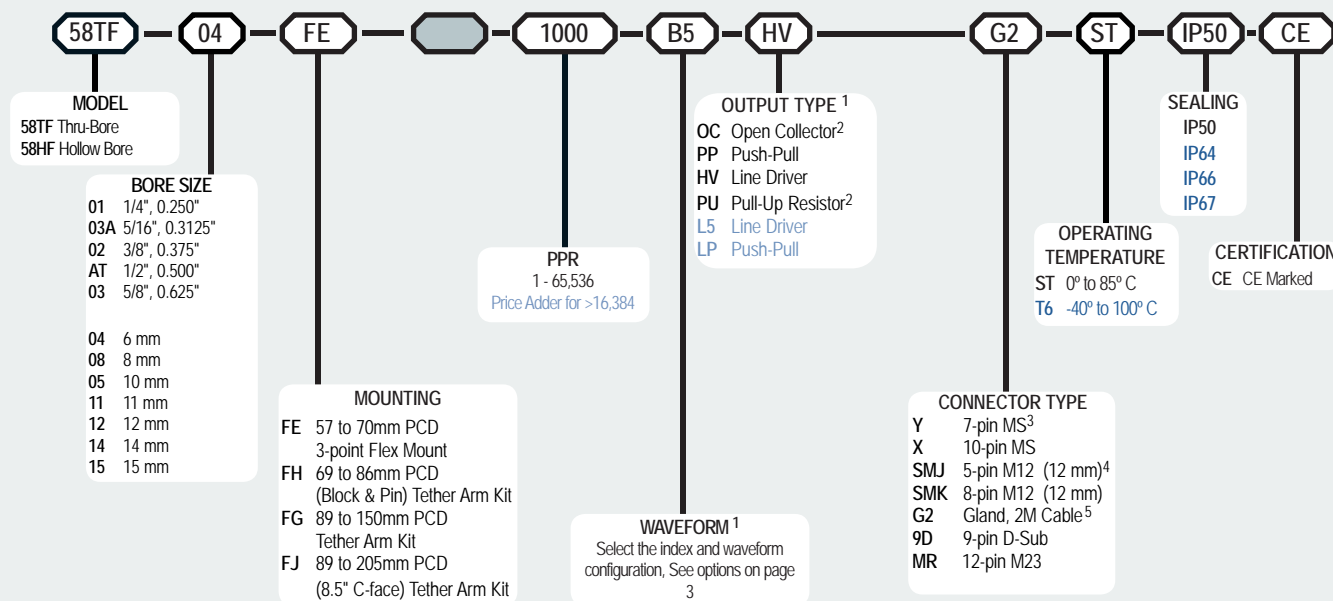

**For specification
assistance call
Customer Service at
+44 (0)1978 262100**

NOTES:

- 1 All output types are 5V to 30V in/out *except* L5 Line Driver and LP Push-Pull output types, which are 5-30VCC in and 5VCC out.
- 2 Open Collector (OC) and Pull-Up Resistor (PU) outputs not recommended for PPR > 8192 and/or frequencies > 150 kHz.
- 3 7-pin MS Connector does not provide Index Pulse Z when selected output is Line Driver (HV or L5).
- 4 5-pin M12 Connectors only available with Pull-Up, Open Collector, and Push-Pull output types.
- 5 For non-standard English cable lengths enter 'G' plus cable length expressed in Meters.
Example: G6 = 6 Meters of cable. Frequency above 300 kHz standard cable lengths only.

Model 58TF Incremental Thru-bore Encoder

Model 58TF Specifications

Electrical

Input Voltage..... 4.75 to 30 Vcc max. See Output Types for limitations

Input Current..... 100 mA max with no output load (65 mA typical)

Output Format..... Incremental, Programmable. See Waveforms on page 3 for options.

Output Types..... **Line Driver* (HV)** – 20 mA max per channel, max freq 1.0 MHz, 5 Vcc max at 100° C or 24 VDC max at 85° C.
Line Driver* (L5) – 5-30 Vcc in/5 Vcc out, 20 mA max per channel, max freq 2.7 MHz, 5 VDC max at 100° C.
Push-Pull (PP) – 20 mA max per channel, max frequency 1.0 MHz, 5 Vcc max at 100° C or 24 Vcc max at 85° C.
Push-Pull (LP) – 5-30 Vcc in/5 Vcc out, 20 mA max per channel, max frequency 2.7 MHz, 5 Vcc max at 100° C.
Open Collector (OC) – 100 mA max per channel, 200 KHz max freq recommended
Pull-Up (PU) – 2.2K ohm internal resistors, 100 mA max per channel, 150 KHz max freq recommended, max temp 85° C at > 24 Vcc
 *Meets RS 422 at 5 Vcc supply

Index..... Once per revolution, programmable. BEPC standard is 180° gated to output A (waveform B5). See Waveform Diagrams for additional options.

Max Frequency..... 2.7 MHz subject to RPM restrictions for high resolution (PPR):
 5000 RPM max for PPR 16385 to 32768 and 2500 RPM max for PPR 32769 to 65536
 NOTE: Use 5 Vcc Line Driver (L5 or HV output type) to obtain high frequencies.

Electrical Protection..... Overvoltage, reverse voltage, and output short circuit protected. NOTE: Sustained over or reverse voltage may result in permanent damage.

CE/EMC..... Immunity tested per EN 61000-6-2:2005
 Emission tested per EN 61000-6-4:2007 + A1: 2011

Rise Time..... Less than 1 microsecond

Accuracy..... Better than 0.013° or 47 arc-sec from true position

Mechanical

Max Shaft Speed..... 6000 RPM. Higher shaft speeds may be achievable, contact Customer Service.

Shaft Material..... 303 Stainless Steel

Shaft Rotation..... Bi-directional

Bore Tolerance..... -0.0000/+0.0254 mm

User Shaft Tolerances
 Radial Runout..... 0.012 max
 Axial Endplay..... ±0.762 max

Starting Torque..... IP50 sealing: 2.118 X 10⁻² Nm typical
 IP64 sealing: 2.824 X 10⁻² Nm typical
 IP66 or IP67 sealing: 4.943 X 10⁻² Nm typical

Housing..... Black non-corrosive finish

Weight..... 283 grams typical

Environmental

Operating Temp..... -20° to 85° C for standard models
 -40° to 100° C for extended temp option

NOTE: For IP66 or IP67 sealing derate max temperature of 100° C by 4° C for every 1000 RPM above 2000 RPM.

Humidity..... 95% RH non-condensing

Vibration..... 10 to 2000 Hz A 20g (International Standard IEC 60068-2-6)

Shock..... 80g @ 6 ms Duration (International Standard IEC 60068-2-27)

Sealing..... IP50 standard; IP64, IP66 or IP67 optional

Model 58TF / 58HF 3 Point Flex Mount (FE)

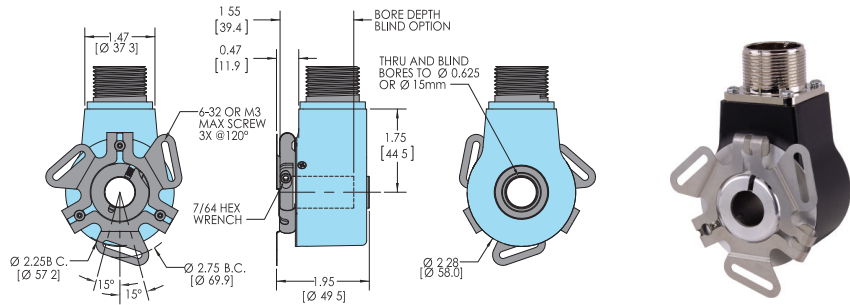

Model 58TF / 58HF Connector Options

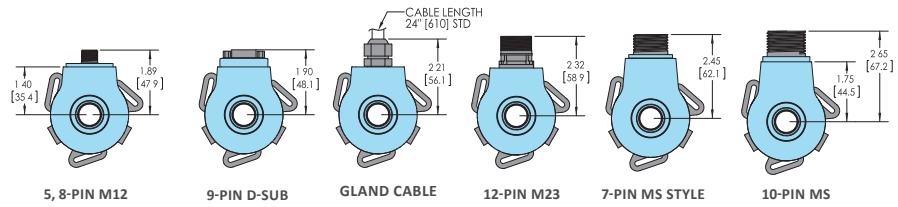

Model 58TF / 58HF Mounting Options

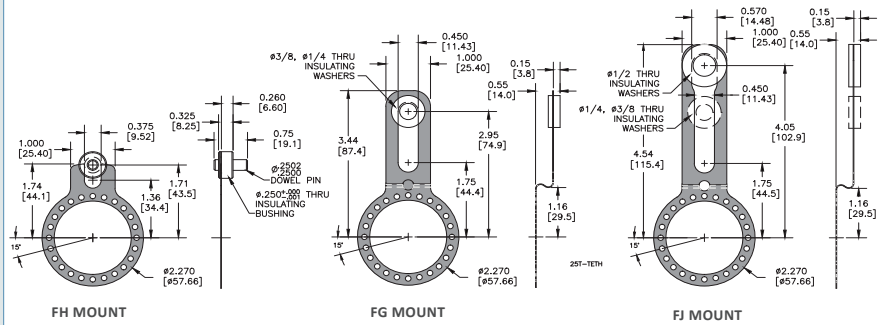

All dimensions are in Imperial & Metric with a tolerance of 0.005" (±0.127mm) or 0.01" (±0.254) unless otherwise specified
 Metric dimensions are in brackets (mm)

ENCODER WIRING TABLE

(For BEPC-supplied mating cables, wiring table is provided with cable.)

Function	Gland Cable ¹ Wire Color	5-pin M12**	8-pin M12**	10-pin MS HV,L5**	7-pin MS HV,L5**	7-pin MS PU,PP,OC,LP**	9-pin D-sub	12-pin M23
0 Volts	Black	3	7	F	F	F	9	10
+VCC	Red	1	2	D	D	D	1	12
A	White	4	1	A	A	A	2	5
A'	Brown	--	3	H	C	--	3	6
B	Blue	2	4	B	B	B	4	8
B'	Violet	--	5	I	E	--	5	1
Z	Orange	5	6	C	--	C	6	3
Z'	Yellow	--	8	J	--	--	7	4
Case	Green	--	--	G	G	G	8	9
Shield	Bare*	Case	Case	--	--	--	--	--
+VCC Sense	--	--	--	--	--	--	--	2
0 Volts Sense	--	--	--	--	--	--	--	11

*CE: Cable shield (bare wire) is connected to internal case.

[†]Standard cable is 24 AWG conductors with foil and braid shield.

**CE: Shield is connected to connector case unless otherwise specified.

