

SHAFT SIZE	∅D	L1	d	L2
6mm	6 [0.236]	12 [0.472]	0.7 [0.028]	10 [0.394]
8mm	8 [0.315]	19 [0.748]	0.5 [0.020]	15 [0.591]
10mm	10 [0.394]	20 [0.787]	no flat	n/a
3/8"	9.5 [0.375]	20 [0.787]	1.2 [0.047]	10 [0.394]

REVISIONS		
REV.	DESCRIPTION	DATE
-	INITIAL RELEASE	8/9/18
A	CHANGED TITLE AND DWG NO ECO 07526	1/11/19
B	NEW CHART FOR SHAFT DIM ECO 07730	9/12/19

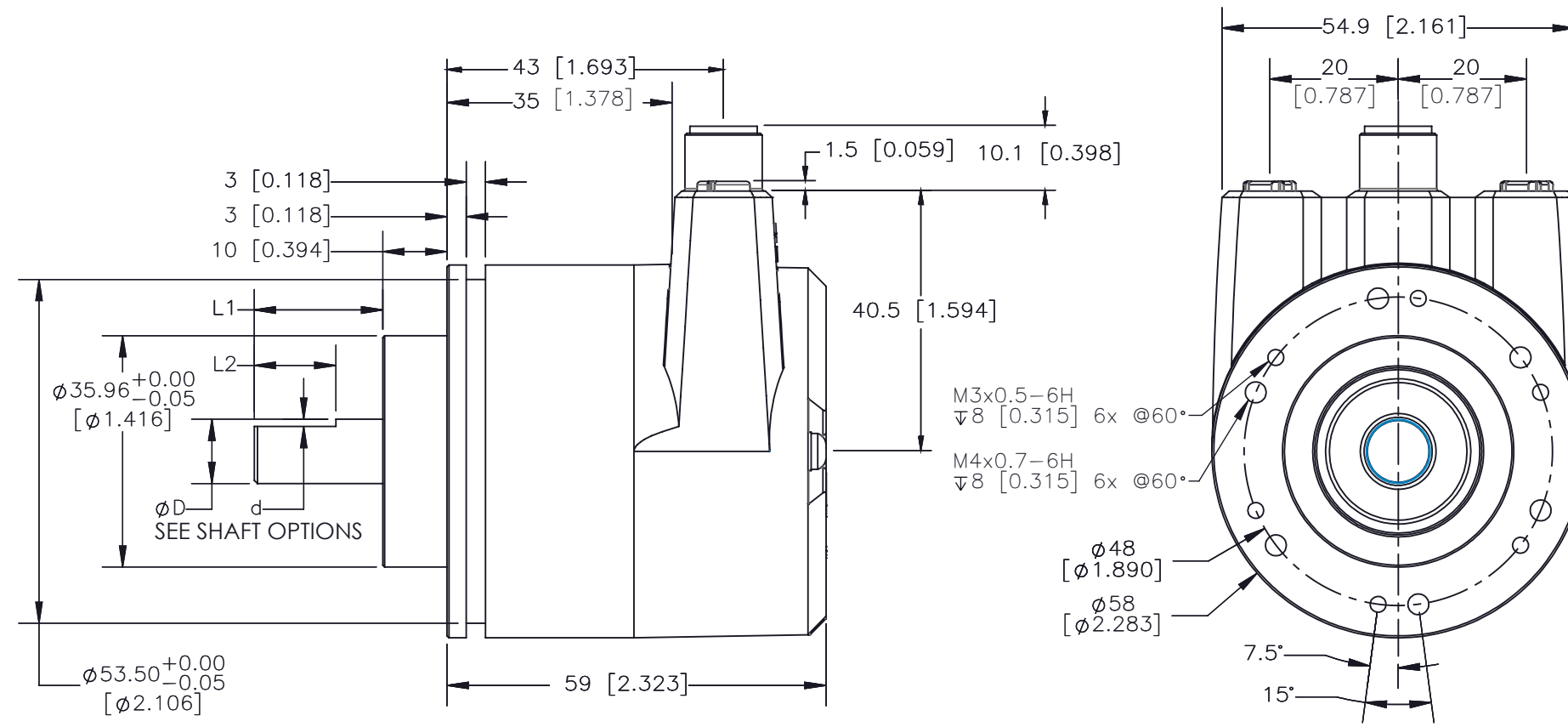

NOTE:  
 Primary dimensions are in mm, secondary dimensions SI units [inches] in brackets for reference only.

THIRD ANGLE PROJECTION				www.encoder.com	
APPROVALS		DATE		NAME AND TITLE	
DRAWN		7/24/18		MODEL A58SE CLAMPING FLANGE	
CHECKED				DWG. NO.	
ISSUE DATE:				A58SE-MH	
NEXT ASSEM.				REV.	
PREV. ASSEM.				B	
PART NUMBER				SCALE: NONE	
				DWG. SIZE: B	
				SHEET 1 OF 1	