



775 Locking Collar Mounting

After carefully unpacking the unit, inspect and ensure that the motor shaft is the correct size and free of all burrs and aberrations.

The maximum recommended motor axial endplay is 0.76mm. (Maximum motor TIR is 0.12mm.)

CAUTION

Do not tighten the 4-40 Allen head screws in the shaft locking collar when the encoder is not installed on a shaft or damage to the clamping collar could occur.

STEP 1

1. Slide the Model 775 encoder over the motor shaft.

DO NOT USE UNDUE FORCE: There may be a rubber O-ring in the locking collar which will provide a small amount of resistance as it engages the motor shaft. If the encoder does not slide on easily, See Note 1 below.

2. The encoder should be positioned approximately 2.52mm from the mounting surface.

3. Install a washer and screw in the anti-rotation flex mount.

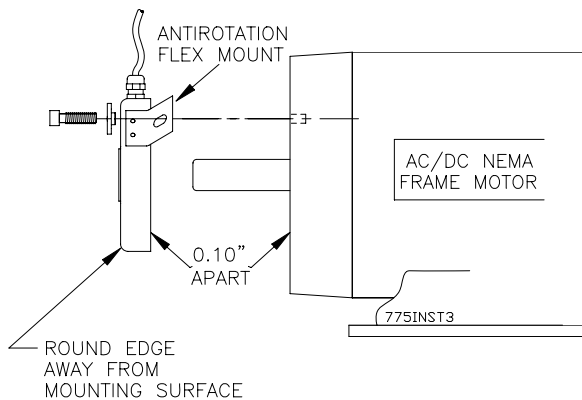

STEP 2

1. Prevent the motor shaft from turning (See Note 2 for additional information)

2. Tighten the four 4-40 socket head screws in the clamping collar evenly in any crossing pattern such as 1 to 2 and 3 to 4. (1.12N-m to 1.35 N-m)

Make sure the screws are securely tightened.

When the motor shaft is turned by hand or operated the

movement in the encoder housing should be very minimal.

3. If the optional shaft cover is included, install it over the shaft and mount it to the encoder housing using the 4-40 screws. Make sure the screws are securely tightened.

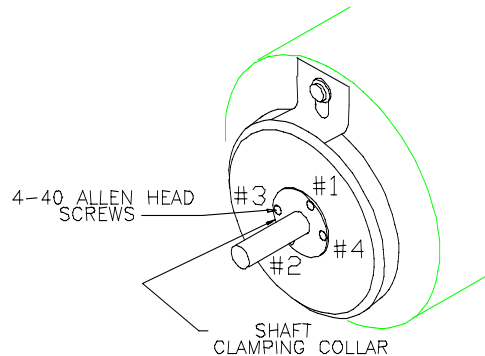

IN CASE OF DIFFICULTY

Note 1: Make sure the 4-40 socket head screws in the front of the encoder locking collar are loose and the collar is not cocked or jammed. Clean the shaft of any burrs using fine crocus cloth. The O-ring in the encoder locking collar may need a small amount of additional lubrication.

Note 2: When tightening the screws in the locking collar, avoid holding the motor shaft with anything that may scar or burr the shaft. Installing temporary screws in the two tapped 4-40 holes in the shaft locking collar may provide a means to keep the shaft from rotating while the four locking collar screws are tightened.

REMOVAL

1. If the optional shaft cover is installed, remove it by removing the 4-40 screws that hold it in place.

2. Loosen (do not remove) the four 4-40 socket head screws in the front of the locking collar. Then remove the anti-rotation flex mount screw and slide the encoder off.

If you have questions regarding this Technical Bulletin, please call Technical Support at +44(0)1978 262100 or email steve.dixon@encoder.co.uk

TB-501.doc, Rev E, 05/02/02, BEPC Version