

Model TR3 - Heavy Duty Tru-Trac™ Encoder and Spring Loaded Measuring Wheel



Features

- Heavy Duty Encoder And Measuring Wheel Solution Integrated Into One Industrial Strength Unit
- Spring Loaded Torsion Arm Makes Wheel Pressure Adjustments A Snap
- Easily Installed In A Vertical, Horizontal, or Upside-Down Orientation
- Operates Over A Variety Of Surfaces At Speeds Up To 3000 Feet Per Minute
- Integrated Module Simplifies Your System Design, Reducing Cost

The TR3 Heavy Duty Tru-Trac™ is an integrated heavy duty encoder and spring loaded measuring wheel assembly all in one, easy-to-use, compact unit. Available in a single, or optional dual-wheel format, the TR3 Heavy Duty Tru-Trac™ is a versatile solution for tracking velocity, position or distance over a wide variety of surfaces in almost any industrial application. Its spring loaded torsion arm provides a simple-to-adjust torsion load, allowing the TR3 Heavy Duty Tru-Trac™ to be mounted in any orientation, even upside-down. The TR3 Heavy Duty Tru-Trac™ housing is an all metal work horse, specifically designed to take on your toughest application environments at operating speeds up to 1000M per minute. Just one look and it's easy to see the TR3 Heavy Duty Tru-Trac™ is the ideal solution for countless applications.

Common Applications

Lumber, Corrugated, Converting, Metal Roll Forming, Paper Monitoring, Glue Dispensing, Linear Material Monitoring, Conveyor Systems, Printing, Labeling, Mining, Construction

Model TR3 - Tru-Trac™ Ordering Guide

Blue type indicates price adder options. Not all configuration combinations may be available. Contact Customer Service for details.

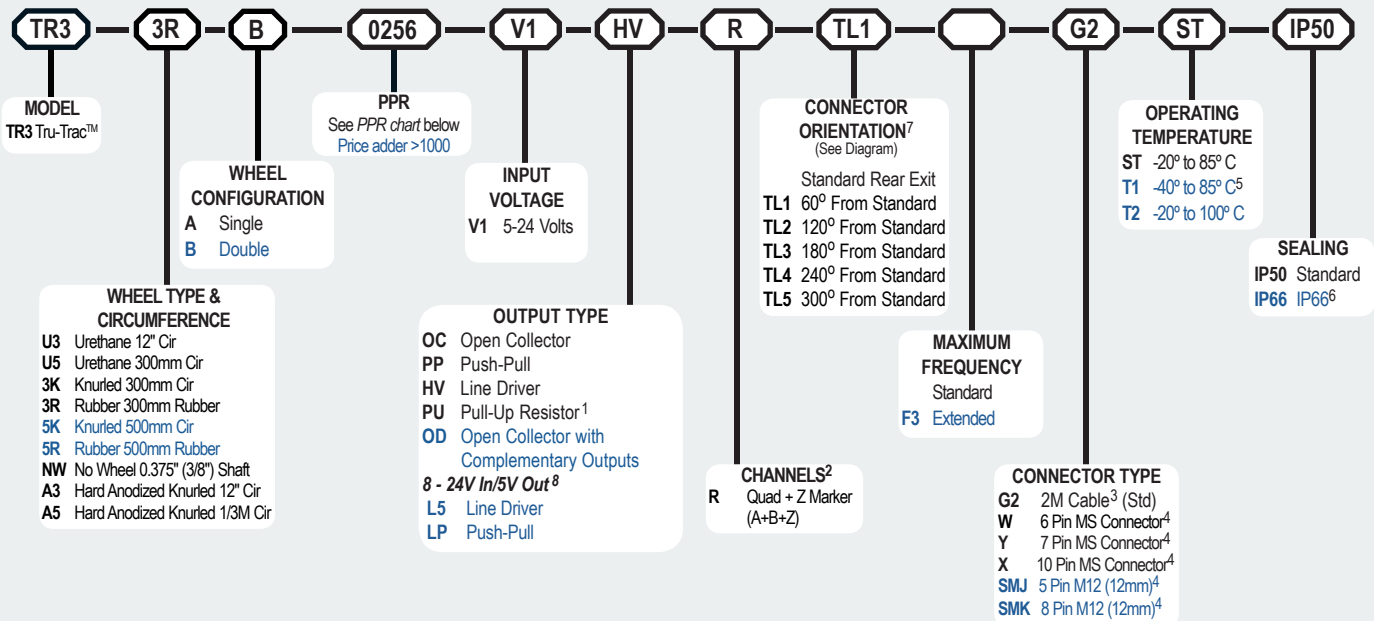

For specification assistance call
Customer Service at
+44 (0)1978 262100

Optional Accessories Mounting Bracket (Stock #176389-01) and Double Pivot (Stock #176391-01) for TR3 Heavy Duty Tru-Trac™ can be ordered separately.

Model TR3 - Tru-Trac™ PPR Options

0001 thru 0189*	0198	0200	0250
0256	0300	0315	0360
0500	0512	0580	0600
0800	1000	1024	1125
1250	1500	1800	2000
2500	2540	3000	3600
4096	5000	6000	7200
10,000			8192

Contact Customer Service for other disc resolutions.

New PPR values are periodically added to those listed. Contact Customer Service to determine all currently available values. Special disc resolutions are available upon request and may be subject to a one-time NRE fee.

NOTES:

- 1 With Input Voltage above 16 Vcc, operating temperature is limited to 85° C.
- 2 Contact Customer Service for non-standard marker gating or phase relationship options.
- 3 For non-standard cable lengths contact sales for availability and cost.
- 4 Body Mount Connector options only available with connector orientation options L1 thru L5.
- 5 Rated to -40° C during encoder operation. Storage and startup below -25° C not recommended.
- 6 Increased starting torque for IP66 option.
- 7 Leave blank for standard cable exit.
- 8 Standard temperature only, Not available with commutation.

Model TR3 - Heavy Duty Tru-Trac™ Encoder and Spring Loaded Measuring Wheel

Model TR3 - Specifications

Electrical

Input Voltage.....	5 to 28 Vcc max for temperatures up to 85° C 5 to 24 Vcc for temperatures between 85° C to 100° C
Input Current.....	140 mA max (65 mA typical) with no output load
Output Format.....	Incremental- Two square waves in quadrature with channel A leading B for clockwise shaft rotation, as viewed from the wheel side. See <i>Waveform Diagrams</i> below.
Output Types.....	Open Collector- 20 mA max per channel Push-Pull- 20 mA max per channel Pull-Up- Open collector with 2.2K ohm Pull-Up 20mA max per channel Line Driver- 20 mA max per channel (Meets RS 422 at 5 Vcc supply)
Index.....	Once per revolution. 0401 to 10,000 PPR: Gated to output A 0001 to 0400 PPR: Ungated See <i>Waveform Diagrams</i> below.
Max. Frequency.....	Standard Frequency Response is 200 kHz for PPR 1 to 2540 500 kHz for PPR 2541 to 5000 1 MHz for PPR 5001 to 10,000 Extended Frequency Response (optional) is 300 kHz for PPR 2000, 2048, 2500, and 2540
Noise Immunity.....	Tested to BS EN61000-6-2; BS EN50081-2; BS EN61000-4-2; BS EN61000-4-3; BS EN61000-4-6, BS EN500811
Symmetry.....	180° (±18°) electrical
Quad. Phasing.....	90° (±22.5°) electrical
Min. Edge Sep.....	67.5° electrical
Accuracy.....	Within 0.017° mechanical or 1 arc-minute from true position. (for PPR>189)

Mechanical

Max Linear Speed...	3000 FPM not to exceed a maximum shaft speed of 6000 RPM.
Shaft Material.....	Stainless Steel
Shaft Size.....	Ø.375"
Radial Shaft Load ..	Up to 5kg max. Controlled by spring torsion feature
Starting Torque.....	7.06 x 10 ⁻³ Nm for IP50 2.82 x 10 ⁻² Nm for IP65 seal
Electrical Conn.....	2M cable (foil and braid shield, 24 AWG conductors) 6-, 7-, or 10-pin MS style, 5- or 8-pin M12 (12mm)
Mounting.....	15.87mm diameter thru hole with clamp
Housing.....	Powder coated aluminum
Wheel Width.....	Up to 20mm
Weight.....	1.15kg typical with single wheel 1.40kg typical with dual wheel

Environmental

Operating Temp.....	-20° to +85° C for standard models -40° to +85° C for low temperature option 20° to +100° C for high temperature option
Storage Temp.....	-25° to +85° C
Humidity.....	98% RH non-condensing
Vibration.....	10 g @ 58 to 500 Hz
Shock.....	80 g @ 11 ms duration
Sealing.....	IP50 standard; IP65 available

Model TR3 - Heavy Duty Tru-Trac™

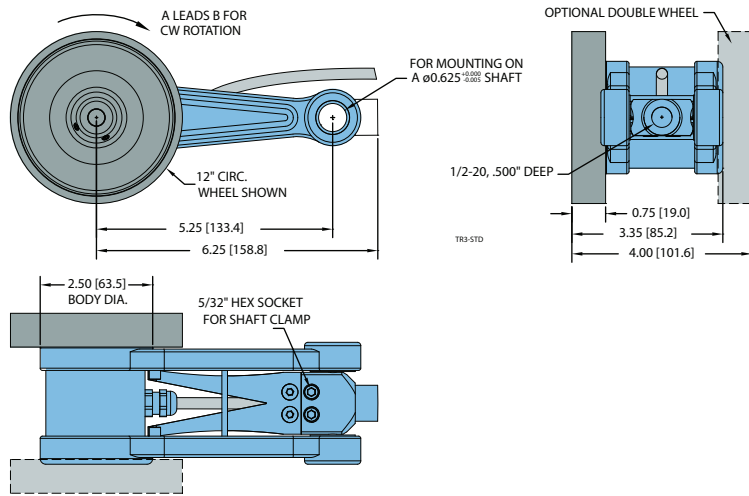

Model TR3 - Mounting Bracket (Order #176389-01)

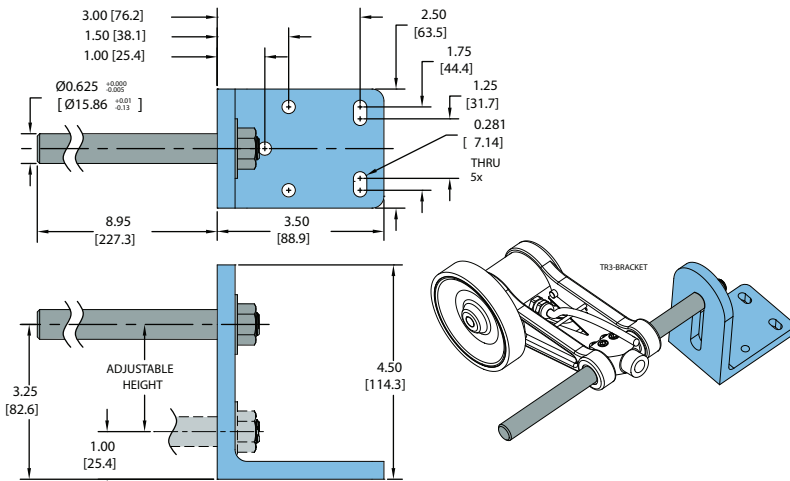

All dimensions are in mm with a tolerance of ±0.127mm or ±0.254 unless otherwise specified



Model TR3 -Heavy Duty Tru-Trac™ Encoder and Spring Loaded Measuring Wheel

Model TR3 Double Wheel Pivot (Order #176391-01)

ALLOWS UNIT TO ROTATE FREELY TO MAINTAIN EQUAL PRESSURE ON BOTH WHEELS, ACCOMMODATING UNEVEN/ ANGLED SURFACES AND MOUNTING MISALIGNMENT

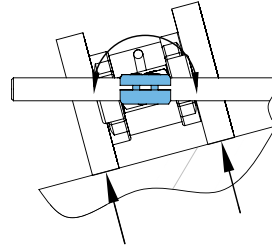
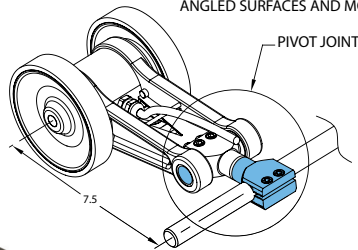

Connector Orientation

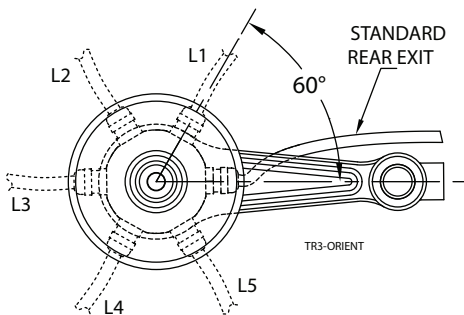

Wiring Table

Function	Gland Cable† Wire Color	5-pin M12** PP,OC,PU	8-pin M12** HV,L5	8-pin M12** OC,PP,PU	6 Pin MS** PU,OC,PP	7 Pin MS** HV,L5	7 Pin MS** PU,OC,PP	10 Pin MS** HV,L5
0 Volts	Black	3	7	7	A, F	F	F	F
+VCC	White	1	2	2	B	D	D	D
A	Brown	4	1	1	D	A	A	A
A'	Yellow	--	3	--	--	C	--	H
B	Red	2	4	4	E	B	B	B
B'	Green	--	5	--	--	E	--	I
Z	Orange	5	6	6	C	C	C	C
Z'	Blue	--	8	--	--	--	--	J
Shield	Bare*	Case	Case	8	Case	G	G	G

*CE: Cable shield (bare wire) is connected to internal case.

†Standard cable is 24 AWG conductors with foil and braid shield.

**CE: Shield is connected to connector case unless otherwise specified.

Connector Pinouts

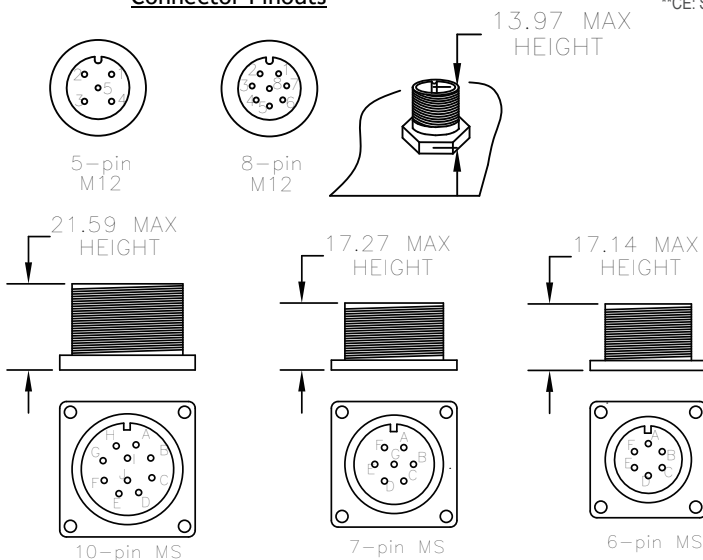

Waveform Diagram

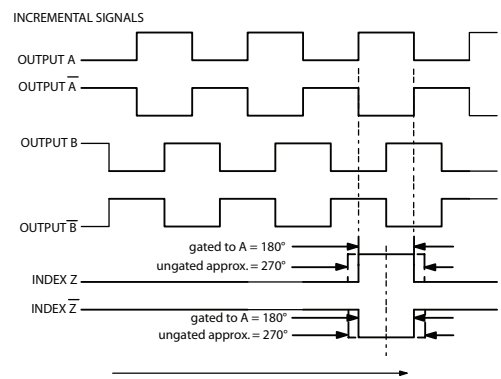

Clockwise rotation as viewed from the single wheel side.
Note: All degree references are electrical degrees.
Waveform shown with optional complementary signals A, B, Z for HV and OD outputs only.

Measuring Wheels: Increasing the Versatility of Encoders

When properly selected and installed, measuring wheel encoders can provide years of trouble free and cost effective performance. In many types of applications, wheeled encoders can provide more convenient installations and higher accuracy than shaft or hollow bore encoders. The basic components of a completely integrated measuring wheel solution include: the encoder, the measuring wheel(s), a spring mechanism to apply a wheel load and a pivot mounting bracket. There are many important considerations when selecting a measuring wheel encoder but two of the more significant decisions will be the number of wheels needed as well as what type of wheel will best suit the application's environment.

A single measuring wheel may be the only option for your application, depending on the width of the material being measured. Single measuring wheels must be aligned perpendicular to the material to avoid error induced by uneven wear and a change in the wheel's effective turning diameter. Double measuring wheels result in twice the traction, reducing the potential for wheel slippage, and when coupled with a pivot mount that allows the encoder to rotate freely, the measuring wheels will align with the measured material and maintain equal pressure on both wheels. BEPC's TR3 has this option, and more.

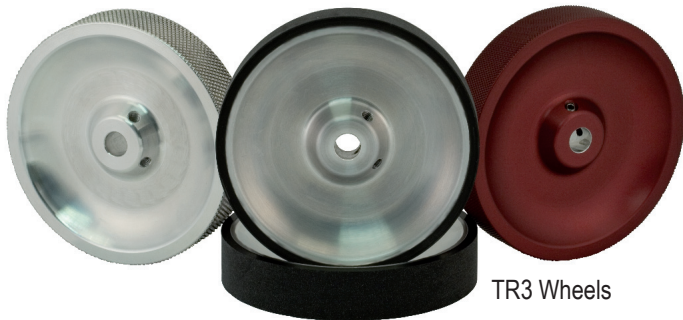

Important factors in selecting the best measuring wheel are the circumference and the surface material. The surface material must be chosen to give optimal traction without unduly compromising wear, while the circumference should be selected to give the best accuracy within the mounting constraints available. BEPC offers many different measuring wheel sizes, including but not limited to 6", 12", 1/3 meter, 200 mm, 500mm and all with a choice of either rubber, knurled or knurled anodized styles, and are made of aluminum alloy.

The actual selection of the various materials is determined by the type of material that is to be measured. The rubber offers the best traction in most applications, but it can be short lived with some materials. The 80 urethane is somewhat harder than the rubber and usually lasts longer. The 90 urethane is the hardest of the coated wheels and provides the longest life under the most circumstances at the cost of less traction. Performance may vary depending on your application.

Another important consideration to keep in mind when selecting a measuring wheel encoder is that it is capable of handling both the mechanical and electrical speed of your application. For Instance, BEPC's model TR1 can handle applications with linear speeds up to 3000 feet per minute and electrical frequencies up to 1 MHz.



Debris collecting on a measuring wheel will increase the effective diameter of the wheel and cause potentially unacceptable error. If there will be significant debris in your application, it is best to install the measuring wheel encoder in a location that is least likely to have the debris collect on the wheel. Rather than mounting the measuring wheel on the top surface of a conveyor belt, mount it upside down and on the interior surface of the belt. If not possible, then installing a brush on the measured material just ahead of the wheel, or in contact with the wheel itself can reduce or even eliminate this problem.

For long service life a measuring wheel encoder should be selected that will withstand the environment in which it will be exposed. All measuring wheels, like BEPC's Accu-Coder™ brand encoders, are manufactured to BEPC's exacting standards, and feature BEPC's exclusive 3-year standard product warranty, ensuring you years of trouble free use.

Check out our complete list of measuring wheels on page 123

For specification assistance call Customer Service at +44 (0)1978 262100