

Model A36R - Absolute Thru / Blind-Bore Encoder



BiSS
INTERFACE Ø36.0 mm

SSI
Synchronous Serial Interface

Features

- Single turn/multi-turn absolute encoder (22 Bit ST / 24 Bit MT)
- High resolution, high accuracy, high performance
- BiSS C or SSI communication protocols
- Up to 10 mm thru-bore or blind hollow bore
- Optional extended temperature range -40° C to 120° C
- Internal temperature sensor (with BiSS C protocol)
- Optional battery/backup power interface for data retention in the absence of primary power

This high-performance thru-bore absolute encoder offers BiSS C or SSI communication protocols in a compact mechanical package. Reflective optical technology guarantees high performance and accuracy. The Model A36R includes customer-accessible non-volatile memory for storing motor name plate data in servo applications. The XXL multi-turn option adds a low power turns-counting circuit offering a variety of backup options including BEPC's embedded battery cable, which has a long-life battery built directly into the controller-end of the cable. The number of possible configurations makes this 36 mm thru-bore or blind hollow bore absolute encoder versatile for many applications.

Common Applications

Robotics, Servo and Stepper Motors, Autonomous Guided Vehicles, Telescopes, Antennas, Wind Turbines, Medical Scanners, Elevators, Lifts, Rotary and X/Y Positioning Tables, Linear Actuators

For specification assistance call
Customer Service at
+44 (0)1978 262100

Model A36R Ordering Guide

Blue type indicates price adder options. Not all configuration combinations may be available. Contact Customer Service for details.

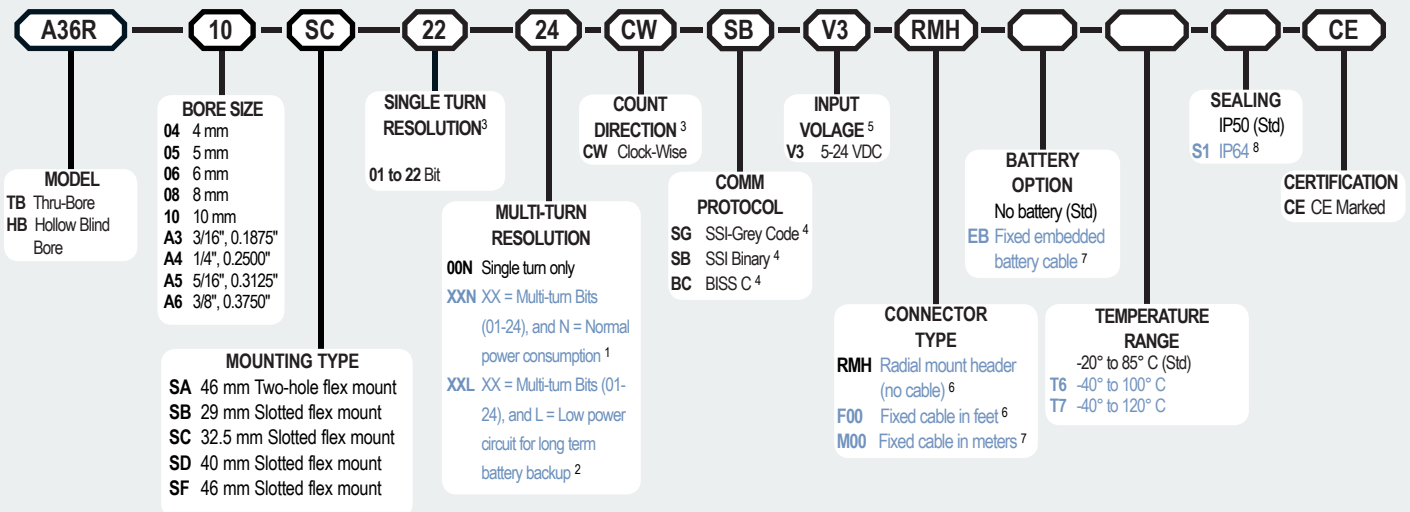

- NOTES:
- 1 The Normal power option is intended for applications where multi-turns counting data does not need to be retained after a power interruption. This option does not include the low power circuit required to maintain turns counting during a power interruption. Turns counting data is retained when a back-up or UPS power source is available to power the entire encoder. Please refer to the A36R Technical Reference Manual for detailed information.
 - 2 The Low power option includes a low power circuit inside the encoder to track and maintain the turns counting data during power interruptions. A small battery or power source, external to the encoder maintains turns counting data.
 - 3 The count direction must be specified at time of order and may not be changed later.
 - 4 Please refer to the A36R Technical Reference Manual at encoder.co.uk
 - 5 See Input Voltage under Specifications (next page) for max temperature ratings.
 - 6 For fixed cable lengths, enter F (feet) or M (meters) plus cable length. Example: F02 = 2 feet of cable or M02 = 2 meters of cable. For mating connectors, cables, and cord sets see Model A36R at encoder.co.uk
 - 7 The fixed embedded battery cable is only available for Low power circuit encoders. Minimum total cable length for EB option is 30 cm (1 foot).
 - 8 Only available for blind hollow bore Model A36RHB with fixed cable. Not available for RMH connector.

Model A36R - Absolute Thru / Blind-Bore Encoder

Model A36R Specifications

Electrical

Input Voltage	4.75-24 VDC max for temp up to 85° C 4.75-20 VDC max for temp up to 100° C 4.75-5.5 VDC max for temp > 100° C
Power Consumption	2.0 W max
Electrical Protection	Transient Overvoltage, Reverse, and Short Circuit
Code	Gray or Binary for SSI; Binary for BiSS C
Resolution (Single)	01 to 22 bit
Resolution (Multi)	01 to 24 bit, and battery backed option
Position Sensor Update	≤ 5 μs
Sensing Method	Optical
Internal Temp. Sensor (TJ)	-40° to 140° C (not accessible with SSI protocol)
NV Memory	4096 Bytes for customer motor name plate data, etc.
Accuracy	Better than 45 ArcSec from True Position
Repeatability	20 ArcSec between repeat moves to any position
CE/EMC	Immunity tested per EN 61000-6-2:2019 Emissions tested per EN 61000-6-4:2019

Battery (XXL only)

Battery supply voltage (at V_{BAT+})	3.05 - 5.5 V
Battery supply current, no +VDC	7 μA with no shaft movement > 7 μA with shaft movement ²
Battery supply current, with +VDC	< 10 nA
Recommended min battery capacity	800 mAh
¹ 3.6V recommended. Voltage at V_{BAT+} ≤ 3.15 V will trigger a battery warning, ≤ 3.05 V will trigger a battery error and cause the encoder to lose MT count. Battery monitoring only active while suitable +VDC supply is present.	
² Current draw with shaft movement dependent on shaft speed. See manual for details.	

SSI Protocol
SSI stands for Synchronous Serial Interface. SSI is an RS 422 serial interface widely used with absolute encoders and controllers in a master slave configuration. SSI encoders offer an all-digital, unidirectional point-to-point connection. For more detailed information see the A36R Technical Reference Manual at encoder.com.

BiSS C Interface
BiSS C stands for Bidirectional Serial Synchronous, Continuous mode interface. BiSS C is similar to SSI and can be used uni-directionally like SSI; however, BiSS C also supports bidirectional communication and operates at speeds up to 10 Mbts/sec. BiSS C can address internal registers in the encoder that can be read and written to by the master, allowing configuration and monitoring of the encoder not possible with uni-directional communication. Reads and writes can be performed by the master on demand, without interfering with real-time operation. This communication protocol is used by industrial automation devices and a common high speed reliable digital solution between absolute encoders and motion controllers. For more detailed information see the A36R Technical Reference Manual at encoder.com

Mechanical

Max Shaft Speed	8,000 RPM; higher speeds may be achievable, contact Customer Service.
User Shaft Radial Runout	0.13 mm [0.005"]
User Shaft Axial Endplay	0.76 mm [0.030"]
Starting Torque	IP50 Blind Hollow Bore: 0.0007 N-m [0.1 oz-in] IP50 Thru-Bore: 0.0021 N-m [0.3 oz-in] IP64 Blind Hollow Bore: 0.0014 N-m [0.2 oz-in]
Weight	50 g (1.8 oz typical)
Shaft Type	Up to 10 mm thru-bore or blind hollow bore
Moment of Inertia	4.2 gm-cm ² (5.9 x 10 ⁻⁵ oz-in-sec ²)

Environmental

Operating Temp	-40° to 120° C (see Input Voltage for limitations)
Storage Temp	-20° to 85° C
Humidity	98% RH non-condensing
Vibration	20 g, 10 to 2000 Hz (according to IEC 60068-2-6)
Shock	100 g @ 11 ms duration (according to MIL-STD-202G 213B)
Sealing	IP50 (DIN EN 60529); IP64 optional

Model A36R 46 mm Slotted flex mount (SF) (Shown with RMH Connector)

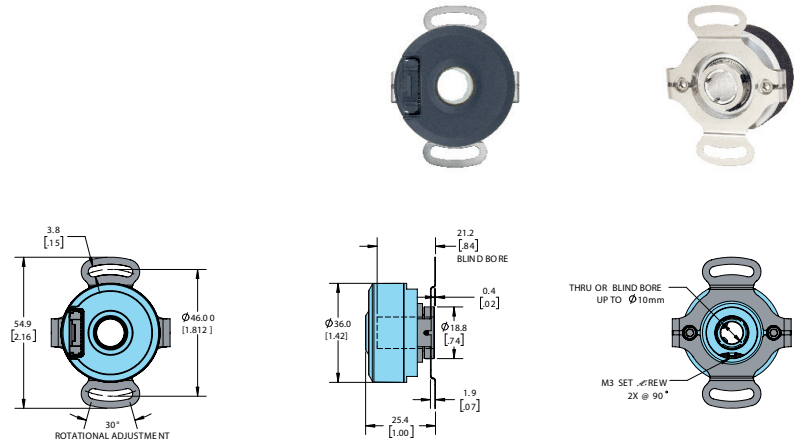

Model A36R 46 mm Two-Hole Flex Mount (SA) Shown with Fixed Cable

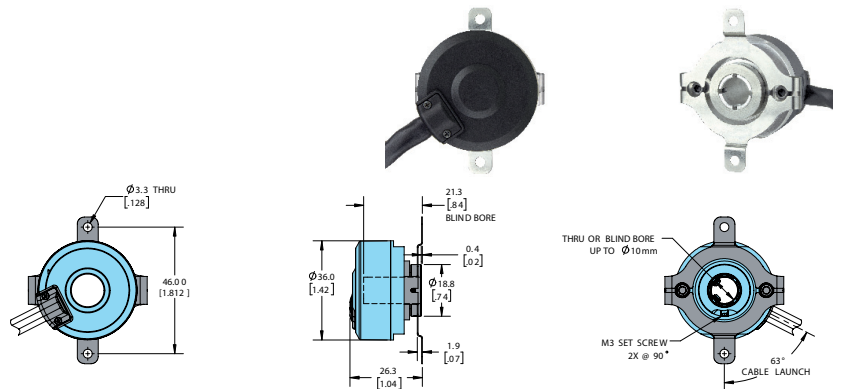

MODEL A36R SMALL DIAMETER SLOTTED FLEX MOUNTS

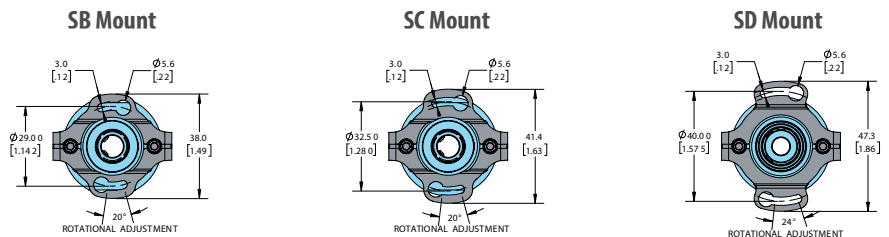

Encoder length and diameter are the same as SF and SA mounts detailed above.
Primary dimensions are in mm, secondary dimensions SI units[inches] in brackets for reference only.
All dimensions have a tolerance of ±0.25mm unless otherwise specified.

MOUNTING AND INSTALLATION KIT

*Order appropriate no charge Mounting and Installation Kit for SB, SC, or SD option. Each kit contains 10 screws for mounting 5 encoders.

- 176150-01 Installation Kit, 4-40 buttonhead screws with 0.062" shortened hex wrench
- 176149-01 Installation Kit, M2.5 buttonhead screws with 1.5 mm shortened hex wrench

Model A36R - Absolute Thru / Blind-Bore Encoder

WIRING TABLES

Single turn or multi-turn N (Normal Power)

Header Pin #	Function	Wire Color
1	NC	--
2	NC	--
3	+VDC	White
4	Com	Violet
5	Position Preset	Brown
6	Shield**	Bare
7	Data -	Orange
8	Data +	Blue
9	Clock -	Yellow
10	Clock +	Green

Multi-turn L (Low Power)

Header Pin #	Function	Wire Color
1	VBAT +	Red†
2	VBAT -*	Black†
3	+VDC	White
4	Com*	Violet
5	Position Preset	Brown
6	Shield**	Bare
7	Data -	Orange
8	Data +	Blue
9	Clock -	Yellow
10	Clock +	Green

*Pins are electrically connected within encoder.

†For Single turn and Normal power multi-turn encoders, the external power wires (red and black) are not used.

**CE Option: Cable shield (bare wire) is connected to internal case.

CONNECTORS

Radial Mount Header (RMH option, shown)

Molex part # 5055671031

Mating Connector

Molex part # 5055651001

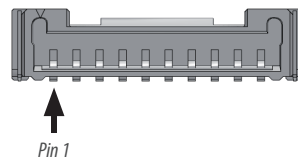

CABLE OPTIONS

Power-ready cable

For multi-turn low power (L) option, user supplies external power.

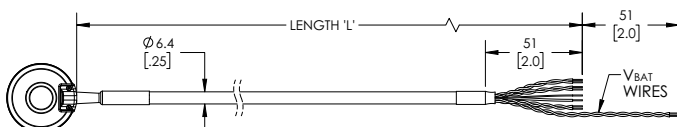

Embedded battery cable

For multi-turn low power (L) option with Embedded Battery Cable option (EB), battery supplies external power.

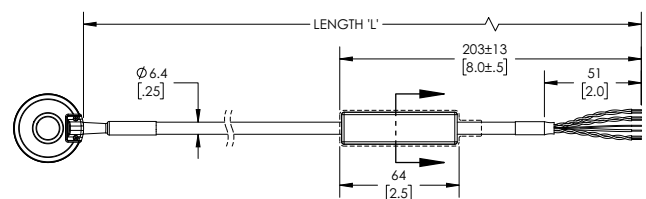

Battery notes:

1. The battery section of the cable is rigid and non-flexible.
2. Battery is located close to the customer end of the cable, and is housed in a protective enclosure secured directly to the cable.
3. Maximum rated battery operating temperature is 85°C.
4. Minimum total cable length for EB option is 30 cm (1 foot).

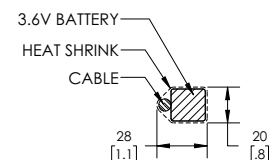

BEPC RESERVES THE RIGHT TO UPDATE, REVISE AND AMEND ALL SOFTWARE AND TECHNICAL DATA OR CONTENT AT ANY TIME. EPC SHALL HAVE NO LIABILITY OF ANY KIND OR NATURE FOR ANY TECHNICAL ERRORS OR OMISSIONS IN ANY SOFTWARE OR TECHNICAL DATA.

See encoder.co.uk for more information.

Model A36R with Reflective Encoder Technology

New!! - Model A36R absolute thru-bore encoder with Reflective Sensor Technology!

The Model A36R absolute encoder is the newest member of BEPC's line of encoders. Its blue LED and reflective sensor technology delivers accurate, high resolution motion feedback in a compact package. Below is an overview of the Technology and its advantages.

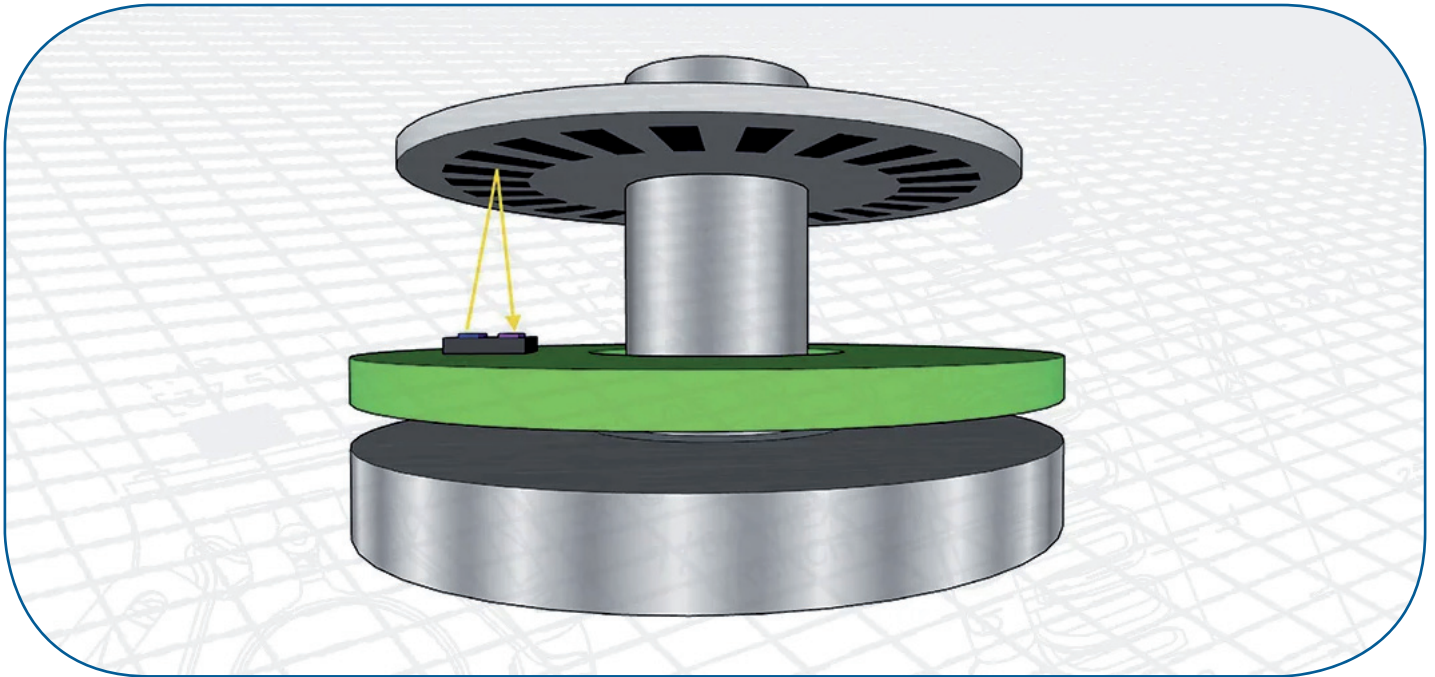

Transmissive optical encoders

MOST OPTICAL ENCODERS ARE based on a transmissive optical architecture. This approach employs a high-quality LED light source that shines through a transmissive encoder disc and is received by a separate detector IC on the opposite side.

Reflective optical encoders

BEPC's newest encoder series utilizes reflective optical technology. In this approach, the LED and detector are located next to each other. The LED light shines onto a reflective disc and the reflected light waves are received by the adjacent sensor..

Reflective encoders with magnetic sensing

For absolute encoder applications that require a persistent multi-turn count, BEPC offers an additional magnetic sensing option. The magnetic sensing system keeps track of the coarse multi-turn count in parallel with the optical sensor. However, the magnetic sensor is a special low-power device that can operate efficiently from an external power source when the primary power source is removed (a battery or controller with a UPS backup may be used). While operating from battery, the magnetic sensing system will remember the last multi-turn count value and track any additional turns that occur until primary power is restored.

Advantages of reflective technology encoders

The primary component of the BEPC reflective technology architecture is an innovative system-on-chip optical device. It combines a blue LED emitter and sensor into one package and also offers a variety of on-chip programmable encoder functions. This new reflective technology offers important advantages over the traditional optical transmissive approach used in encoders:

- A very compact design is possible because only a single PCB assembly is required instead of the two PCB assemblies needed when using transmissive technology.
- The short wavelength of the embedded blue LED improves signal contrast reducing jitter and the combined assembly of the emitter and sensor minimizes optical crosstalk. This allows for higher resolution, greater accuracy, and better performance.
- Most magnetic encoders utilize magnets located at the end of the encoder shaft to detect position. Reflective technology allows for off-axis position detection, allowing for more versatile mounting options including thru-bore style shafts.