

Model 770 Thru-Bore Encoder



Ø165.1 mm

Features

- Slim Profile - Only 25.4mm Deep
- Fits NEMA Size 56C Thru 184C Motor Faces (114.3mm AK)
- Incorporates Opto-ASIC Technology
- Resolutions to 4096 PPR

The Model 770 C-face encoder is a rugged, high resolution encoder designed to mount directly on NEMA C-face motors. Both sides of the encoder are C-face mounts, allowing additional C-face devices to be mounted to this encoder. Unlike many C-face kit type encoders, the Model 770 contains precision bearings and an internal flex mount, virtually eliminating encoder failures and inaccuracies induced by motor shaft runout or axial endplay. The advanced Opto-ASIC design provides advanced noise immunity necessary for many industrial applications. This encoder is ideal for applications using induction motors and flux vector control. The Model 770 provides speed and position information for drive feedback in a slim profile - only 25.4mm thick. The Thru-Bore design allows fast and simple mounting of the encoder directly to the accessory shaft or to the drive shaft of the motor, using the standard motor face (NEMA sizes 56C - 184C). The tough, all metal housing resists the vibration and hazards of an industrial environment.

Common Applications

Motor Feedback, Velocity & Position Control, Conveyors, Variable Speed Drives, Mixing & Blending Motors, Assembly & Speciality Machines

Model 770 Ordering Guide

Blue type indicates price adder options. Not all configuration combinations may be available. Contact Customer Service for details.

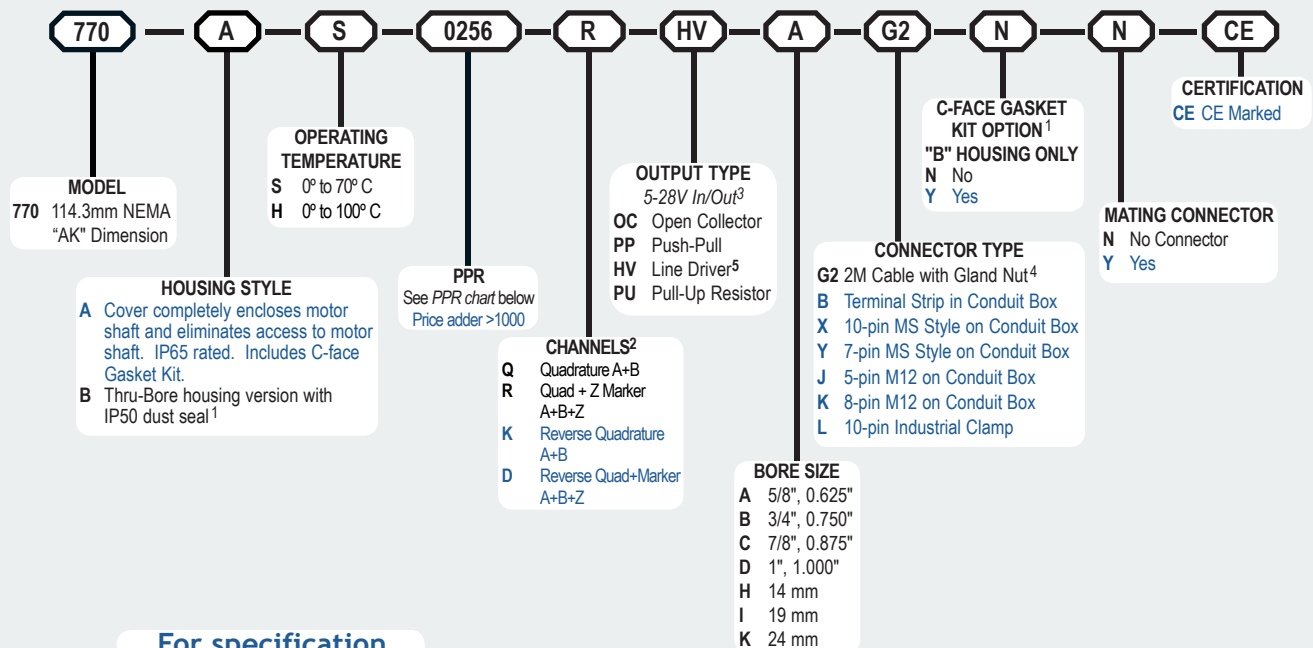

For specification assistance call
Customer Service at
+44 (0)1978 262100

Model 770 PPR Options

0060	0100	0120	0240	0250	0256
0500	0512	1000	1024	2048	2500
4096					

Contact Customer Service for other disk resolutions; not all disk resolutions available with all output types

NOTES:

- 1 Thru-Bore version may be IP65 sealed if mounted between two C-face devices with optional gasket kit. Select 'Yes' under C-face Gasket Kit Option.
- 2 Contact Customer Service for Marker gating options.
- 3 5 to 24 VCC max for high temperature option.
- 4 For non-standard cable lengths, Contact the sales office for more information.
- 5 Not available with 5-pin M12 connector. Available with 7-pin MS connector only without Index Z.

Model 770 Thru-Bore Encoder

Model 770 Specifications

Electrical

Input Voltage.....4.75 to 28 VCC max for temperatures up to 70° C
4.75 to 24 VCC for temperatures between 70° C to 100° C

Input Current.....100 mA max with no output load

Input Ripple100 mV peak-to-peak at 0 to 100 kHz

Output FormatIncremental- Two square waves in quadrature with channel A leading B for clockwise shaft rotation, as viewed from the mounting face. See *Waveform Diagrams* below.

Output TypesOpen Collector- 100 mA max per channel
Pull-Up- 100 mA max per channel
Push-Pull- 20 mA max per channel
Line Driver- 20 mA max per channel (Meets RS 422 at 5 VCC supply)

IndexOnce per revolution.
0513 to 4096 PPR: Gated to output A
0001 to 0512 PPR: Ungated
See *Waveform Diagrams* below.

Max Frequency.....200 kHz

Noise Immunity.....Tested to BS EN61000-4-2; IEC801-3; BS EN61000-4-4; DDENV 50141; DDENV 50204; BS EN55022 (with European compliance option); BS EN61000-6-2; BS EN50081-2

Symmetry180°(±18°) electrical
Quad. Phasing.....90°(±22.5°) electrical
Min. Edge Sep.....67.5° electrical
Rise Time.....Less than 1 microsecond

Mechanical

Max Shaft Speed.....6000 RPM. Higher shaft speeds may be achievable, contact Customer Service.

Bore Size0.625", 0.750", 0.875", 1.000", 14 mm, 19 mm, and 24 mm

Bore Tolerance+0.03/-0.00 mm

User Shaft Tolerances
Radial Runout.....0.127mm
Axial Endplay±1.27mm

Electrical Conn.....Gland nut with 2M cable (foil and braid shield, 24 AWG conductors), Terminal Strip in conduit box, 7- or 10-pin MS Style, 5- or 8-pin M12 (12 mm), 10-pin Industrial Clamp

Housing.....All metal construction
Mounting.....NEMA 56C to 184C
Weight.....1.17kg with gland nut
1.36kg with all other connector options
Note: All weights typical

Environmental

Operating Temp.....0° to 70° C for standard models
0° to 100° C for high temperature option

Storage Temp.....-25° to 100° C

Humidity.....98% RH non-condensing

Vibration.....10 g @ 58 to 500 Hz

Shock.....50 g @ 11 ms duration

Sealing.....IP65 for Option A housing style with gasket kit
IP50 for Option B housing style

Model 770 w/Gland Nut (G2)

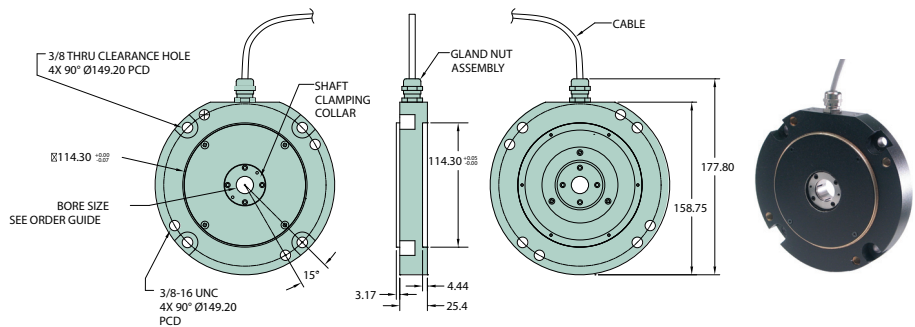

Model 770 w/Conduit Box (B, X, Y, J, K)

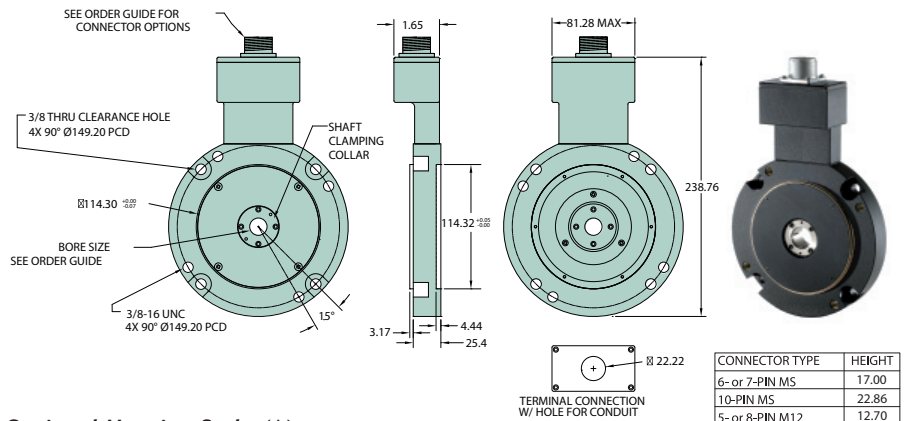

Optional Housing Style (A) Protective Cover

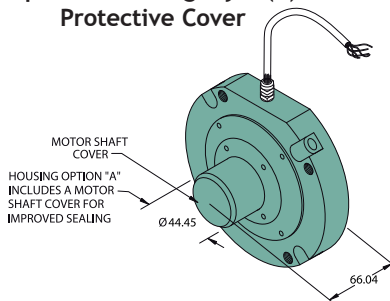

All dimensions are in mm with a tolerance of ±0.254 unless otherwise specified.

Waveform Diagrams

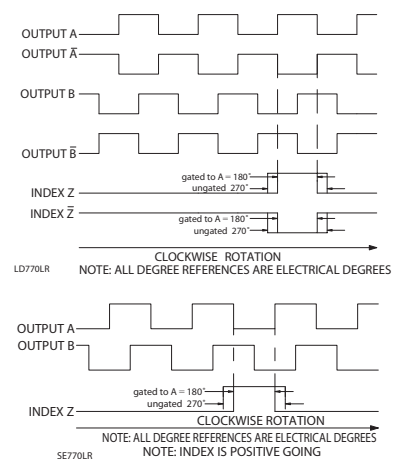

Wiring Table

Function	Gland Cable ¹ Wire Color	5-pin M12** PP,OC,PU	8-pin M12** HVL5	8-pin M12** OC,PP,PU	7 Pin MS** HV	7 Pin MS** PU,OC,PP	10 Pin MS** HV	Terminal Block	10 Pin Indust Clamp
0 Volts	Black	3	7	7	F	F	F	2	1
+VCC	Red	1	2	2	D	D	D	1	6
A	White	4	1	1	A	A	A	3	3
A'	Brown	--	3	--	C	--	H	4	8
B	Blue	2	4	4	B	B	B	5	2
B'	Violet	--	5	--	E	--	I	6	7
Z	Orange	5	6	6	C	C	C	7	4
Z'	Yellow	--	8	--	--	--	J	8	9
Shield	Bare*	Case	Case	8	G	G	G	9	10

*CE: Cable shield (bare wire) is connected to internal case.
¹Standard cable is 24 AWG conductors with foil and braid shield.
 **CE: Shield is connected to connector case unless otherwise specified.